



A1. 主体関係 / Machine body / Maschinengehäuse / Corps de la machine / Cuerpo de la máquina

REF.NO.	CODE	Q'TY	ヒンメイ	NAME OF PARTS	RM
3	104450109	4	ゴムセン8	RUBBER CAP, 8	
4	159928009	1	ゴムセン15	RUBBER CAP, 15	
5	117934009	1	ゴムセン13.5	RUBBER CAP, 13.5	
6	140392009	1	オイルフタ	OIL CAP	
11	104450109	3	ゴムセン8	RUBBER CAP, 8	
12	104449009	1	ゴムセン15.5	RUBBER CAP, 15.5	
13	140392009	1	オイルフタ	OIL CAP	
14	S37915009	1	ベッドカバーR	BED COVER, R	
15	S41675109	1	ベッドカバーL	BED COVER, L	
16	106629002	8	シメネジ4.37	SCREW, SM4.37	
17	062681012	2	ナベコ437-40X10	SCREW, PAN SM4.37-40X10	
18	S41669009	1	アームスペーサ	ARM SPACER	
20	062711212	3	ナベコ476-32X12	SCREW, PAN SM4.76-32X12	
21	S41670009	1	メイタクミ	FACE PLATE ASSY	
21-1	S41671009	1	メイタ	FACE PALTE	
21-2	S41672000	1	メイタガワパツキン	PACKING	
22	062401012	3	ナベコM4X10	SCREW, PAN M4X10	
26	S37920009	1	テンピンカバー	THREAD TAKE-UP COVER	
27	062680612	1	ナベコ4.37-40X6	SCREW, PAN SM4.37-40X6	
29	S42227009	1	グロメツトMG-3	RUBBER CAP, MG-3	
45	S41763009	1	サイドカバーL	SIDE COVER, L	
46	S41764009	1	サイドカバーR	SIDE COVER, R	
47	008300604	8	+トラスコ3X6	SCREW, TRUSS M3X6	
85	S41673001	1	アイガードクミ	EYE GUARD ASSY	
85-1	S36691001	1	アイガードトリツケイタクミ	EYE GUARD SET PLATE ASSY	
85-1-1	S34844001	1	アイガードトリツケイタ	EYE GUARD SET PLATE	
85-1-2	S34845001	1	アイガードドダイ	EYE GUARD BASE	
85-1-3	S36071001	1	アイガードシテンネジ	EYE GUARD SCREW	
85-1-4	S36070001	1	アイガードモッドシバネ	EYE GUARD SPRING	
85-1-5	106129002	1	ナツト3.57	NUT, SM3.57	
85-2	S41674000	1	アイガード	EYE GUARD	
85-3	100257010	2	シメネジ3.57	SCREW, SM3.57	
85-4	106129002	2	ナツト3.57	NUT, SM3.57	
86	062670512	2	ナベコ3.57-40X5	SCREW, PAN SM3.57-40X5	
37	018061236	3	ボルトM6X12	BOLT, SOCKET M6X12	
38	025060236	3	ワッシャー	WASHER, PLAIN	
39	104833009	1	ゴムセン4.3	RUBBER CAP, 4.3	
40	S41762009	1	モーターベース750	MOTOR BASE, 750	
41	018062036	4	ボルトM6X20	BOLT, SOCKET M6X20	
42	028060246	4	ワッシャー	WASHER, SPRING 2-6	
43	025060236	4	ワッシャー	WASHER, PLAIN M6	
44	104450109	4	ゴムセン8	RUBBER CAP, 8	
48	S41765009	1	リアカバー	REAR COVER	
49	008400504	5	+トラスコM4X6	SCREW, TRUSS M4X6	
50	S41767000	81	ブロアファン	BLOW FAN	
51	S31704000	1	エアチューブ4X1200	AIR TUBE 4X1200	
52	025070230	1	ナイロンランプNK-2N	CORD HOLDER NK-2N	
53	062400616	01	ナベコM4X6	SCREW, PAN M4X6	
54	S41768001	15	ベアリング	BEARING	
55	S41769001	2	ヒンジシャフトサエ	HINGE SHAFT SUPPORT	
56	018403036	8	ボルトM4X30	BOLT, SOCKET M4X30	
57	104821009	1	ゴムセン10.5	RUBBER CAP, 10.5	
58	017086006	1	ボルトM8X60	BOLT, M8X60	
59	213650001	1	ワッシャー2.3X8.5X38ST	WASHER, 2.3X8.5X38ST	
60	028080246	1	ワッシャー	WASHER, SPRING 2-8	
61	021080206	62	ナツト	NUT, SM8	
62	158830001	2	ヒンジピン	HINGE PIN	
63	158831001	2	ヒンジピン	HINGE PIN	
64	048080342	2	メフEB	RETAINING RING, EB	

From the library of: Diamond Needle Corp

A2. 主体関係 / Machine body / Maschinengehäuse / Corps de la machine / Cuerpo de la máquina

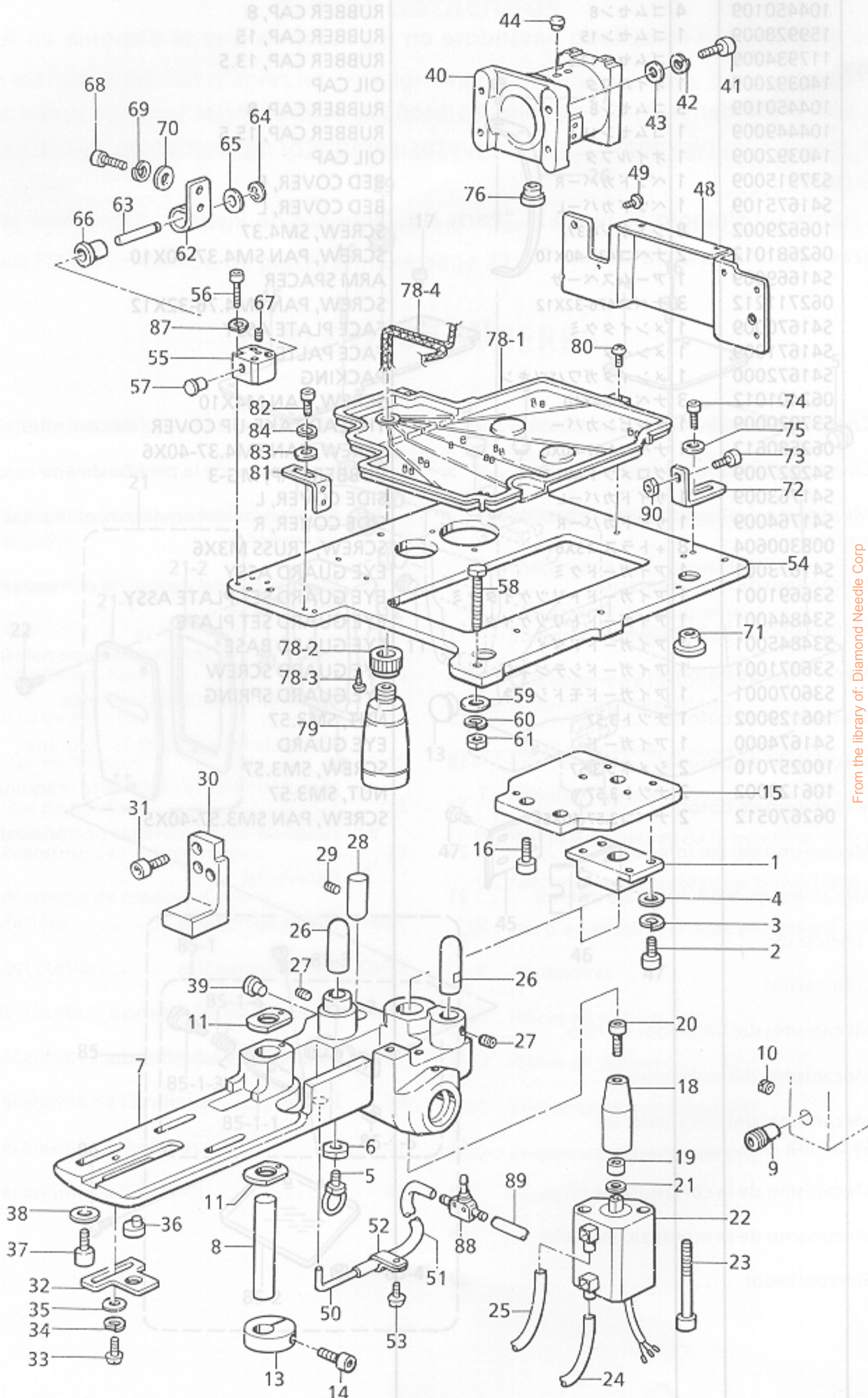

From the library of: Diamond Needle Corp

A2. 主体関係 / Machine body / Maschinengehäuse / Corps de la machine / Cuerpo de la máquina

REF.NO.	CODE	Q'TY	ヒンメイ	NAME OF PARTS	RM
1	S41745001	1	イチギメジクウケ	POSITIONING BEARING	
2	018501236	4	アナボルト5X12	BOLT, SOCKET M5X12	
3	028050246	4	バネザガネ2-5	WASHER, SPRING 2-5	
4	025050236	4	ヒラザガネチユウ5	WASHER, PLAIN M 5	
5	S41746000	1	アイボルト	EYE BOLT	
6	021060206	1	2シユナツト6	NUT, 2 M6	
7	S41747009	1	BMササエダイ	BM SUPPORT BASE	
8	S41748001	1	BMササエシテンジク	BM SUPPORT FULCRUM SHAFT	
9	149996001	1	ストップカムセットネジ	STOP CAM SET SCREW	
10	105299003	1	トメネジ6.35	SET SCREW, SM6.35	
11	S41749001	2	スラストザガネ16	THRUST WASHER, 16	
13	S41750001	1	カラー16	COLLAR, 16	
14	018061636	1	アナボルト6X16	BOLT, SOCKET M6X16	
15	S41751001	1	ソコイタ	BOTTOM PLATE	
16	018501036	3	アナボルト5X10	BOLT, SOCKET M5X10	
18	S41752001	1	BMササエスライドジク	BM SUPPORT SLIDE SHAFT	
19	S41753001	1	スパーサ5.6	SPACER, 5.6	
20	018061636	1	アナボルト6X16	BOLT, SOCKET M6X16	
21	S03695001	1	ザガネ6	WASHER, PLAIN 6	
22	S41754000	1	スライドシリンダクミ	SLIDE CYLINDER ASSY	
23	S14473000	2	CQ2ボルトM5X60	BOLT, CQ2 M5X60	
24	S41940000	1	エアホース0425S124B	AIR TUBE, (L = 1240)	
25	S18387004	1	エアチューブ	AIR TUBE, (L = 1300)	
26	S41757001	2	BMササエダイスベリジク	BM SUPPORT BASE SLIDE SHAFT	
27	012060636	4	アナヒラ6X6	SET SCREW, SOCKET (FT) M6X6	
28	S41758001	1	BMササエRスベリジク	SLIDE SHAFT, BM SUPPORT (R)	
29	012060636	2	アナヒラ6X6	SET SCREW, SOCKET (FT) M6X6	
30	S41759001	1	BMササエR	BM SUPPORT, R	
31	018501236	3	アナボルト5X12	BOLT, SOCKET M5X12	
32	S41760001	1	スライドイタ	SLIDE PLATE	
33	062401016	1	ナベコ4X10	SCREW, PAN M4X10	
34	028040246	1	バネザガネ2-4	WASHER, SPRING 2-4	
35	025040236	1	ヒラザガネチユウ4	WASHER, PLAIN M 4	
36	S41761001	1	BMタイチヨウセツジク	ADJUSTING SHAFT, BM BASE	
37	018061236	3	アナボルト6X12	BOLT, SOCKET M6X12	
38	025060236	3	ヒラザガネチユウ6	WASHER, PLAIN M 6	
39	104833009	1	ゴムセン4.3	RUBBER CAP, 4.3	
40	S41762009	1	モーターダイ750	MOTOR BASE, 750	
41	018062036	4	アナボルト6X20	BOLT, SOCKET M6X20	
42	028060246	4	バネザガネ2-6	WASHER, SPRING 2-6	
43	025060236	4	ヒラザガネチユウ6	WASHER, PLAIN M 6	
44	104450109	4	ゴムセン8	RUBBER CAP, 8	
48	S41765009	1	ウシロカバー	REAR COVER	
49	008400604	5	+トラスコ4X6	SCREW, TRUSS M4X6	
50	S41767000	1	ブローパイプ	BLOW PIPE	
51	S31704000	1	エアチューブ4X1260	AIR TUBE, 4X1260	
52	625010000	1	ナイロンクランプNK-2N	CORD HOLDER, NK-2N	
53	062400616	1	ナベコM4X6	SCREW, PAN M4X6	
54	S41768001	1	ベッドダイ	BEAD BASE	
55	S41769001	2	ヒンジジクササエ	HINGE SHAFT SUPPORT	
56	018403036	8	アナボルト4X30	BOLT, SOCKET M4X30	
57	104821009	2	ゴムセン10.5	RUBBER CAP, 10.5	
58	017086006	6	ボルト8X60	BOLT, M8X60	
59	213650001	6	ワ2.3X8.5X38ST	WASHER, 2.3X8.5X38ST	
60	028080246	6	バネザガネ2-8	WASHER, SPRING 2-8	
61	021080206	6	2シユナツト8	NUT, 2 M8	
62	158830001	2	ヒンジ	BED HINGE	
63	158831001	2	ヒンジピン	PIN	
64	048080342	2	トメワE8	RETAINING RING, E8	

From the library of: Diamond Needle Corp

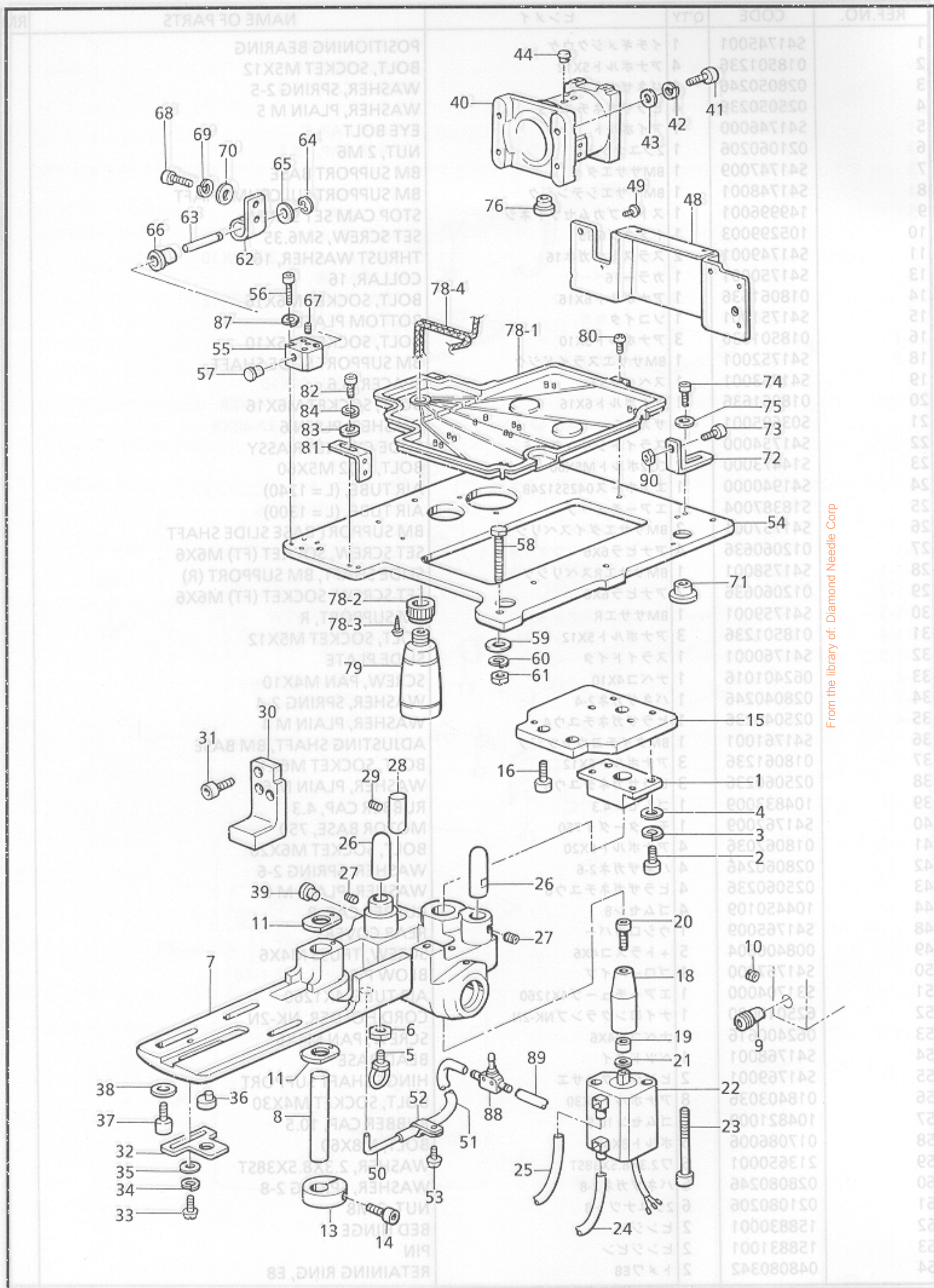

From the library of: Diamond Needle Corp

A2 . 主体関係 / Machine body / Maschinengehäuse / Corps de la machine / Cuerpo de la máquina

REF.NO.	CODE	Q'TY	ヒンメイ	NAME OF PARTS	RM
65	025100132	2	ヒラザガネシヨウ10	WASHER, PLAIN S 10	
66	158832009	2	ヒンジピンササエゴム	HINGE PIN SUPPORTER RUBBER	
67	012060636	2	アナヒラ6X6	SET SCREW, SOCKET (FT) M6X6	
68	018061636	4	アナボルト6X16	BOLT, SOCKET M6X16	
69	028060246	4	バネザガネ2-6	WASHER, SPRING 2-6	
70	025060236	4	ヒラザガネチユウ6	WASHER, PLAIN M 6	
71	S41770009	2	クツシヨン	CUSHION	
72	S41771001	1	ベッドコティダイ	BED SETTING BASE	
73	018061636	1	アナボルト6X16	BOLT, SOCKET M6X16	
74	018401236	2	アナボルト4X12	BOLT, SOCKET M4X12	
75	025040236	2	ヒラザガネチユウ4	WASHER, PLAIN M 4	
76	159928009	1	ゴムセン15	RUBBER CAP, 15	
78	S41772009	1	オイルパンクミ	OIL PAN ASSY	
78-1	S41773009	1	オイルパン	OIL PAN	
78-2	154467001	1	ハイユキヤツブ	DUST OILER	
78-3	037301215	2	Vナベタツピン3X12	TAPPING SCREW, PAN V M3X12	
78-4	S18093100	1	クミヒモ4X4	WICK, 4X4	
79	114486002	1	ポリオイラータイ	OILER	
80	062300616	5	ナベコM3X6	SCREW, PAN M3X6	
81	S41774001	1	センサーダイ	SENSOR BASE	
82	018400836	2	アナボルト4X8	BOLT, SOCKET M4X8	
83	025040236	2	ヒラザガネチユウ4	WASHER, PLAIN M 4	
84	028040246	2	バネザガネ2-4	WASHER, SPRING 2-4	
87	028040246	8	バネザガネ2-4	WASHER, SPRING 2-4	
88	S09197000	1	スピードコントローラ	SPEED CONTROLLER	
89	S14085001	1	エアーチューブ	AIR TUBE, 4X82	
90	021060206	1	2シユナツト6	NUT, 2 M6	
90	062781412	2	ナベコSM6.35-28X14	SCREW, PAN SM6.35-28X14	
91	S41684000	1	ハリボウアンナイフ	NEEDLE BAR GUIDE, F	
92	018501036	2	アナボルト5X10	BOLT, SOCKET M5X10	
93	S41685001	1	ハリボウメタルU	NEEDLE BAR BUSH, U	
94	S41686001	1	ハリボウメタルD	NEEDLE BAR BUSH, D	
95	S41687001	1	ハリボウメタルF	NEEDLE BAR BUSH, F	
96	154627001	1	ハリボウメタルDS	NEEDLE BAR BUSH, DS	
97	018681232	2	ボルトSM4.37-40X12	BOLT, SOCKET SM4.37-40X12	
98	S37940001	1	ピン	LOCATOR PIN	
99	S37928019	2	針ハリDPX17NY	NEEDLE DPX17NY (#21)	
100	S41688000	1	スラストコラー	THRUST COLLAR	
101	014760622	2	セットネジSM5.95	SET SCREW, SOCKET SM5.95	
102	101482001	1	接続ロッド調整用プレート	CONNECTING ROD ADJUSTION PLATE	
103	S41689001	1	ハリボウメタルE	NEEDLE BAR BUSH, E	
104	S41697001	1	ハリボウメタルG	NEEDLE BAR BUSH, G	
104-1	062680812	1	ボルトSM4.37-40X8	BOLT, SOCKET SM4.37-40X8	
106	S41691001	1	ハリボウIP	NEEDLE BAR IP	
107	S41692001	1	補助ハリ	AUXILIARY NEEDLE BAR	
108	S41693001	1	ダブネジ4	SHOULDER SCREW, M4	
109	S41694001	1	ハリボウメタルナイフ	NEEDLE CLAMP GUIDE	
110	S41695001	2	ハリボウメ	NEEDLE CLAMP	
111	018680822	2	ボルトSM4.37X8	BOLT, SOCKET SM4.37X8	
112	110735002	2	ザガネ	WASHER	
113	144458001	2	アタマツキトメネジ3.57	SET SCREW, 3.57	
119	S37928021	2	針ハリDPX17NY	NEEDLE DPX17NY (#21)	

From the library of: Diamond Needle Corp

B. 上軸・針棒関係 / Upper shaft and needle bar mechanism  
 / Obere Welle und Nadelstangenvorrichtung  
 / Mécanisme de arbre supérieur et barra à aiguille  
 / Mecanismo del eje superior y la barra de aguja

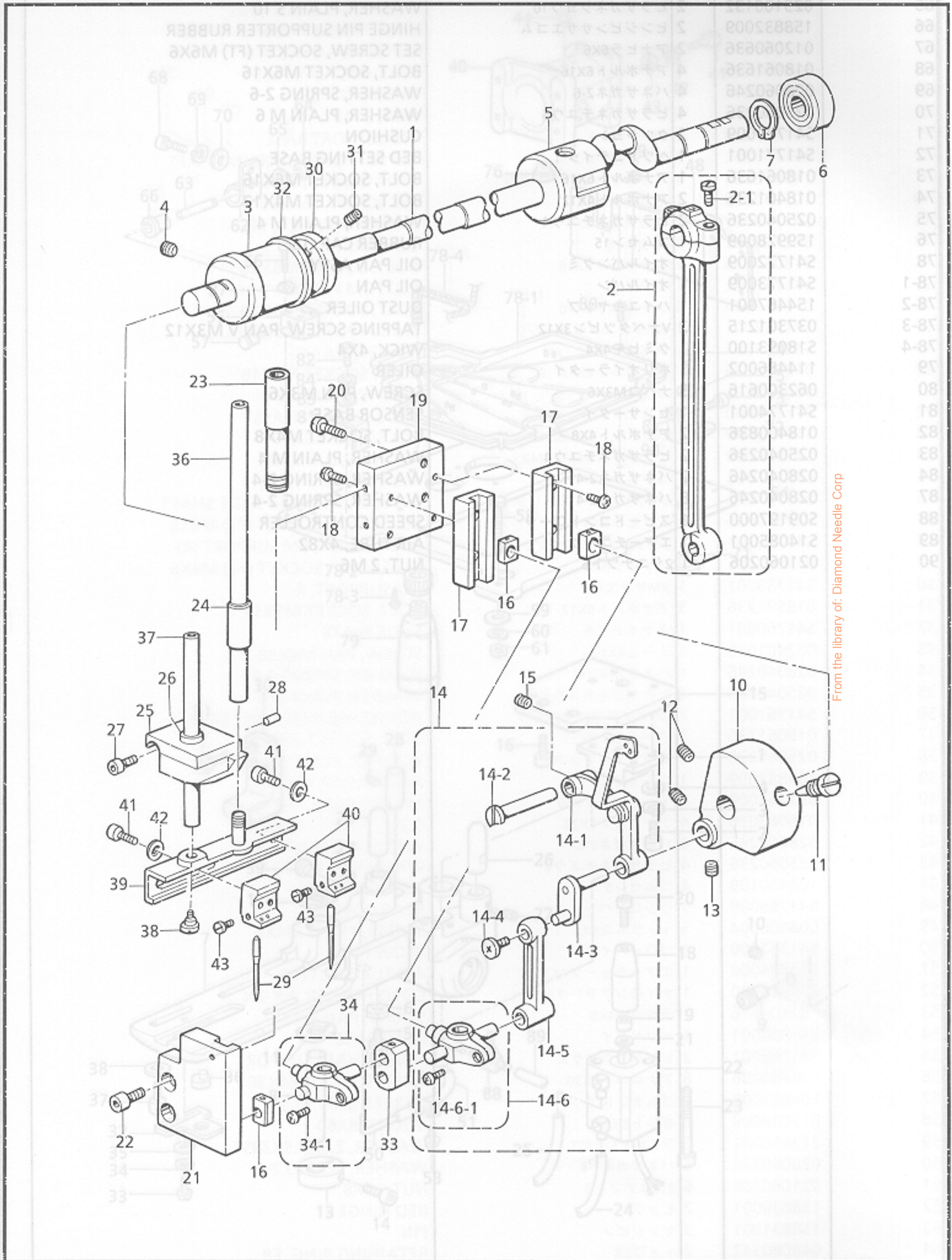

From the library of: Diamond Needle Corp

B. 上軸・針棒関係 / Upper shaft and needle bar mechanism

/ Obere Welle und Nadelstangenvorrichtung

/ Mécanisme de arbre supérieur et barra à aiguille

/ Mecanismo del eje superior y la barra de aguja

NAME OF PARTS

REF.NO.	CODE	Q'TY	ヒンメイ	NAME OF PARTS	RM
1	S41677001	1	ウワジク	UPPER SHAFT	
2	153040001	1	クランクロッドクミ	CRANK ROD ASSY	
2-1	144712001	2	シメネジ4.76	SCREW, SM4.76	
3	S41678001	1	ウワジクメタルF	UPPPER SHAFT BUSH, F	
4	014780622	1	アナトメネジ6.35クボミ	SET SCREW, SOCKET (CP) SM6.35	
5	140726000	1	ウワジクメタルM	UPPER SHAFT BUSH, M	
6	072630260	1	ベアリング6302VV	BALL BEARING, 6302VV	
7	048150142	1	トメワジクヨウC15	RETAINING RING, C15	
10	152231000	1	シリアイクランク	COUNTER WEIGHT	
11	100250001	1	シメネジ7.14	SCREW, SM7.14	
12	014770622	2	アナトメネジ6.35クボミ	SET SCREW, SOCKET (CP) SM6.35	
13	101706001	1	トメネジ6.35	SET SCREW, SM6.35	
14	S41679001	1	ハリボウレンカクミ	THREAD TAKE-UP LEVER ASSY	
14-1	S41680001	1	テンピンクミ	THREAD TAKE-UP ASSY	
14-2	152236001	1	テンピンササエジク	THREAD TAKE-UP SUPPORT STUD	
14-3	152237001	1	ハリボウクランク	NEEDLE BAR CRANK	
14-4	132051001	1	+サラネジ3.57L	SCREW, FLAT SM3.57L	
14-5	152238001	1	ハリボウレンカン	THREAD TAKE-UP LEVER	
14-6	S41696001	1	ハリボウダキ8.72クミ	NEEDLE CLAMP ASSY, 8.72	
14-6-1	062680812	1	ナベコ437-40X8	SCREW, PAN SM4.37-40X8	
15	014760622	1	アナトメネジ5.95	SET SCREW, SOCKET SM5.95	
16	102630001	3	ハリボウアンナイカクコマ	NEEDLE BAR GUIDE SLIDE BLOCK	
17	S37927000	2	ハリボウアンナイ	NEEDLE BAR GUIDE	
18	062670612	4	ナベコ357-40X6	SCREW, PAN SM3.57-40X6	
19	S41683000	1	ハリボウアンナイダイ	NEEDLE BAR GUIDE BASE	
20	062781412	2	ナベコ635-28X14	SCREW, PAN SM6.35-28X14	
21	S41684000	1	ハリボウアンナイF	NEEDLE BAR GUIDE, F	
22	018501036	2	アナボルト5X10	BOLT, SOCKET M5X10	
23	S41685001	1	ハリボウメタルU	NEEDLE BAR BUSH, U	
24	S41686001	1	ハリボウメタルD	NEEDLE BAR BUSH, D	
25	S41687001	1	ハリボウメタルダイF	NEEDLE BAR BUSH BASE, F	
26	154627001	1	ハリボウメタルDS	NEEDLE BAR BUSH, DS	
27	018681232	2	アナボルト437-40X12	BOLT, SOCKET SM4.37-40X12	
28	S37940001	1	イチギメピン	LOCATOR PIN	
29	S37928019	2	ミシンハリDPX17NY	NEEDLE DPX17NY (#19)	
30	S41688000	1	スラストカラー	THRUST COLLAR	
31	014760622	2	アナトメネジ5.95	SET SCREW, SOCKET SM5.95	
32	101482001	1	レンカンシキリイタ	CONNECTING ROD PARTITION PLATE	
33	S41689001	1	ハリボウダキレンカン	NEEDLE BAR CLAMP LEVER	
34	S41697001	1	ハリボウダキ7.94クミ	NEEDLE BAR CLAMP ASSY, 7.92	
34-1	062680812	1	ナベコ437-40X8	SCREW, PAN SM4.37-40X8	
36	S41691001	1	ハリボウIP	NEEDEL BAR, IP	
37	S41692001	1	ホジヨハリボウ	AUXILIARY NEEDLE BAR	
38	S41693001	1	ダンネジ4	SHOULDER SCREW, M4	
39	S41694001	1	ハリドメアンナイ	NEEDLE CLAMP GUIDE	
40	S41695001	2	ハリドメ	NEEDLE CLAMP	
41	018680822	2	アナボルト4.37X8	BOLT, SOCKET SM4.37X8	
42	110735002	2	ザガネ	WASHER	
43	144458001	2	アタマツキトメネジ3.57	SET SCREW, SM3.57	
29	S37947001 S41707001 100645003	2	" オプション部品 "	" OPTION PARTS "	
			ミシンハリDPX17NY	NEEDLE DPX17NY (#21)	

From the library of: Diamond Needle Corp



C1. 送り関係 / Feed mechanism / Transportvorrichtung / Mécanisme de l'entraînement / Mecanismo de la alimentación

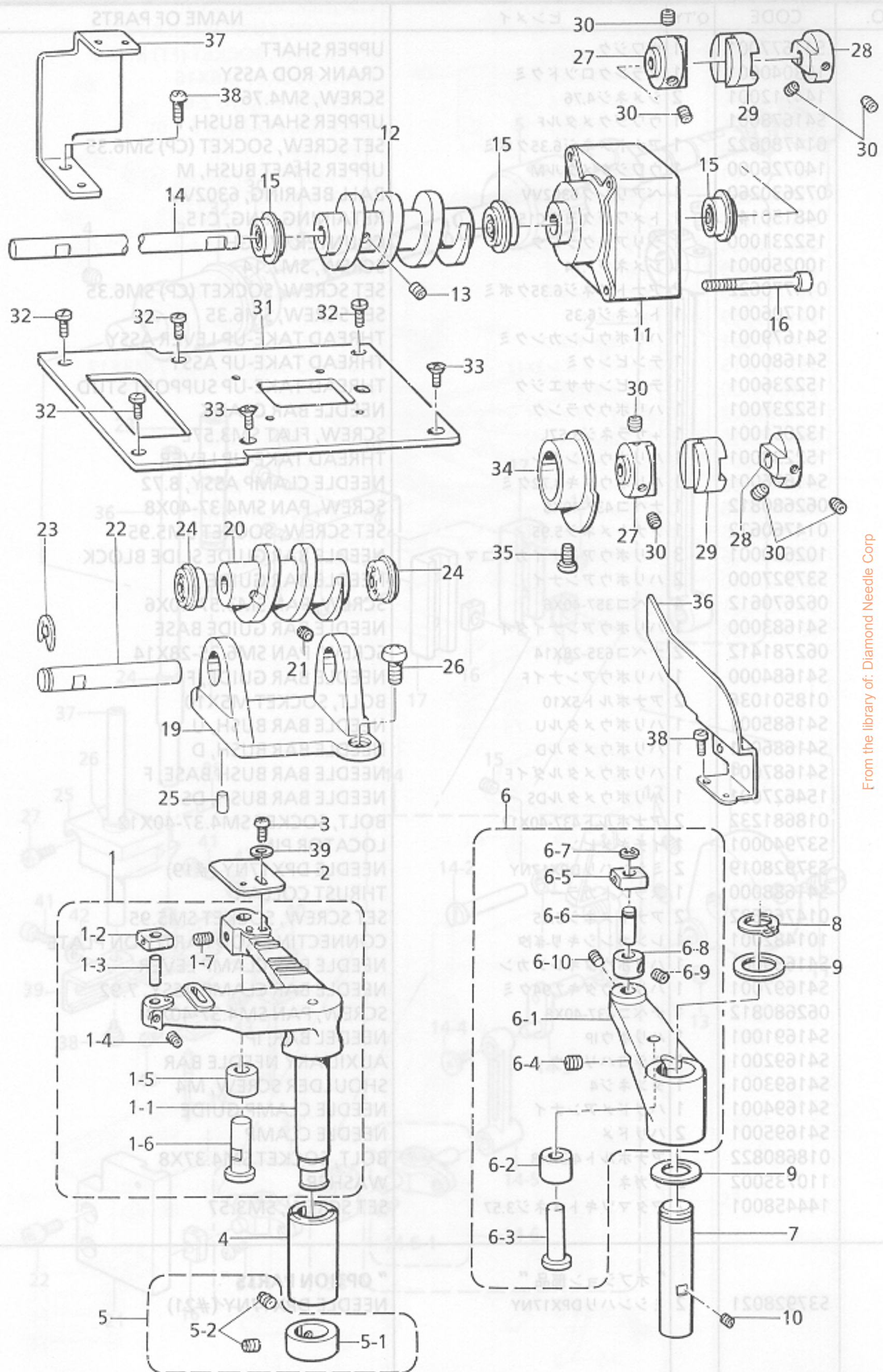

From the library of: Diamond Needle Corp

C1. 送り関係 / Feed mechanism / Transportvorrichtung / Mécanisme de l'entraînement  
/ Mecanismo de la alimentación

REF.NO.	CODE	Q'TY	ヒンメイ	NAME OF PARTS	RM
1	S41698001	1	Xオクリレバークミ	X-FEED LEVER ASSY	
1-1	S41699000	1	Xオクリレバー100	X-FEED LEVER, 100	
1-2	152743001	1	ヨコオクリカクゴマ	TACK LENGTH SLIDE BLOCK	
1-3	156956001	1	リンクジク	LINK SHAFT	
1-4	014760622	1	アナトメネジ5.95	SET SCREW, SOCKET SM5.95	
1-5	S37932001	1	オクリカムコロ	FEED CAM ROLLER	
1-6	S37933001	1	コロジク	ROLLER SHAFT	
1-7	014760622	1	アナトメネジ5.95	SET SCREW, SOCKET SM5.95	
2	S41700001	1	ゲンテンドグX	HOME POSITION DOG, X	
3	062680612	1	ナベコ4.37-40X6	SCREW, PAN SM4.37-40X6	
4	S37934001	1	Xオクリレバークミ	X FEED LEVER BUSH	
5	183493001	1	オクリジクセツトカラー	FEED SHAFT SET COLLAR ASSY	
5-1	S09212001	1	セツトカラー	SET SCREW COLLAR	
5-2	101706001	2	トメネジ6.35	SET SCREW, SM6.35	
6	S41701001	1	Yオクリレバークミ	Y-FEED LEVER ASSY	
6-1	S37936001	1	Yオクリレバー	Y-FEED LEVER	
6-2	S37932001	1	オクリカムコロ	FEED CAM ROLLER	
6-3	S37933001	1	コロジク	ROLLER SHAFT	
6-4	014760622	1	アナトメネジ5.95	SET SCREW, SOCKET SM5.95	
6-5	152743001	1	ヨコオクリカクゴマ	TACK LENGTH SLIDE BLOCK	
6-6	S41702001	1	カクコマジク	SLIDE BLOCK SHAFT	
6-7	048040342	1	トメワE4	RETAINING RING, E4	
6-8	S28090001	1	セツトカラー	SET SCREW COLLAR	
6-9	014680422	1	アナトメネジ4.37クボミ	SET SCREW, SOCKET (CP) SM4.37	
6-10	014760622	1	アナトメネジ5.95	SET SCREW, SOCKET SM5.95	
7	152760001	1	タテオクリレバークミ	TACK WIDTH LEVER SHAFT	
8	048180142	1	トメワジクヨウC18	RETAINING RING, C18	
9	152756001	2	スラストサガネ18	THRUST WASHER, 18	
10	014760622	1	アナトメネジ5.95	SET SCREW, SOCKET SM5.95	
11	S41703000	1	PMブラケットX	PM BRACKET, X	
12	S41704001	1	オクリカムX	FEED CAM	
13	014760622	2	アナトメネジ5.95	SET SCREW, SOCKET SM5.95	
14	S41705001	1	カムジクX	CAM SHAFT, X	
15	070688850	3	タマジクウケ688ZZNR	BALL BEARING, 688ZZNR	
16	018405032	4	アナボルト4X50	BOLT, SOCKET M4X50	
19	S37937001	1	オクリカムブラケット	FEED CAM BRACKET	
20	S37941001	1	オクリカムY	FEED CAM, Y	
21	014760622	2	アナトメネジ5.95	SET SCREW, SOCKET SM5.95	
22	S37939001	1	カムジク	CAM SHAFT	
23	048060342	1	トメワE6	RETAINING RING, E6	
24	070688850	2	タマジクウケ688ZZNR	BALL BEARING, 688ZZNR	
25	S37940001	2	イチギメピン	LOCATOR PIN	
26	062681012	2	ナベコ4.37-40X10	SCREW, PAN SM4.37-40X10	
27	S37942000	2	カップリングハブ8	COUPLING HUB, 8	
28	S37943000	2	カップリングハブ6.35	COUPLING HUB, 6.35	
29	S37944000	2	カップリングスパーサ	COUPLING SPACER	
30	014760622	8	アナトメネジ5.95	SET SCREW, SOCKET SM5.95	
31	S41706001	1	オクリダイアンナイイタ	FEED BAR GUIDE PLATE	
32	145318001	4	シメネジ4.37	SCREW, SM4.37	
33	100032004	2	サラネジ4.37	SCREW, FLAT SM4.37	
34	S37946001	1	オクリゲンテンドグ	FEED HOME POSITION DOG	
35	062300512	1	ナベコ3X5	SCREW, PAN M3X5	
36	S37947001	1	ゲンテンセンサートリツケイタ	HOME POSITION SENSOR SET PLATE	
37	S41707001	1	Xセンサートリツケイタ	X-SENSOR SET PLATE	
38	062680612	2	ナベコ4.37-40X6	SCREW, PAN SM4.37-40X6	
39	100645003	1	ザガネ	WASHER	

From the library of: Diamond Needle Corp

C2. 送り関係 / Feed mechanism / Transportvorrichtung / Mécanisme de l'entraînement  
 / Mecanismo de la alimentación

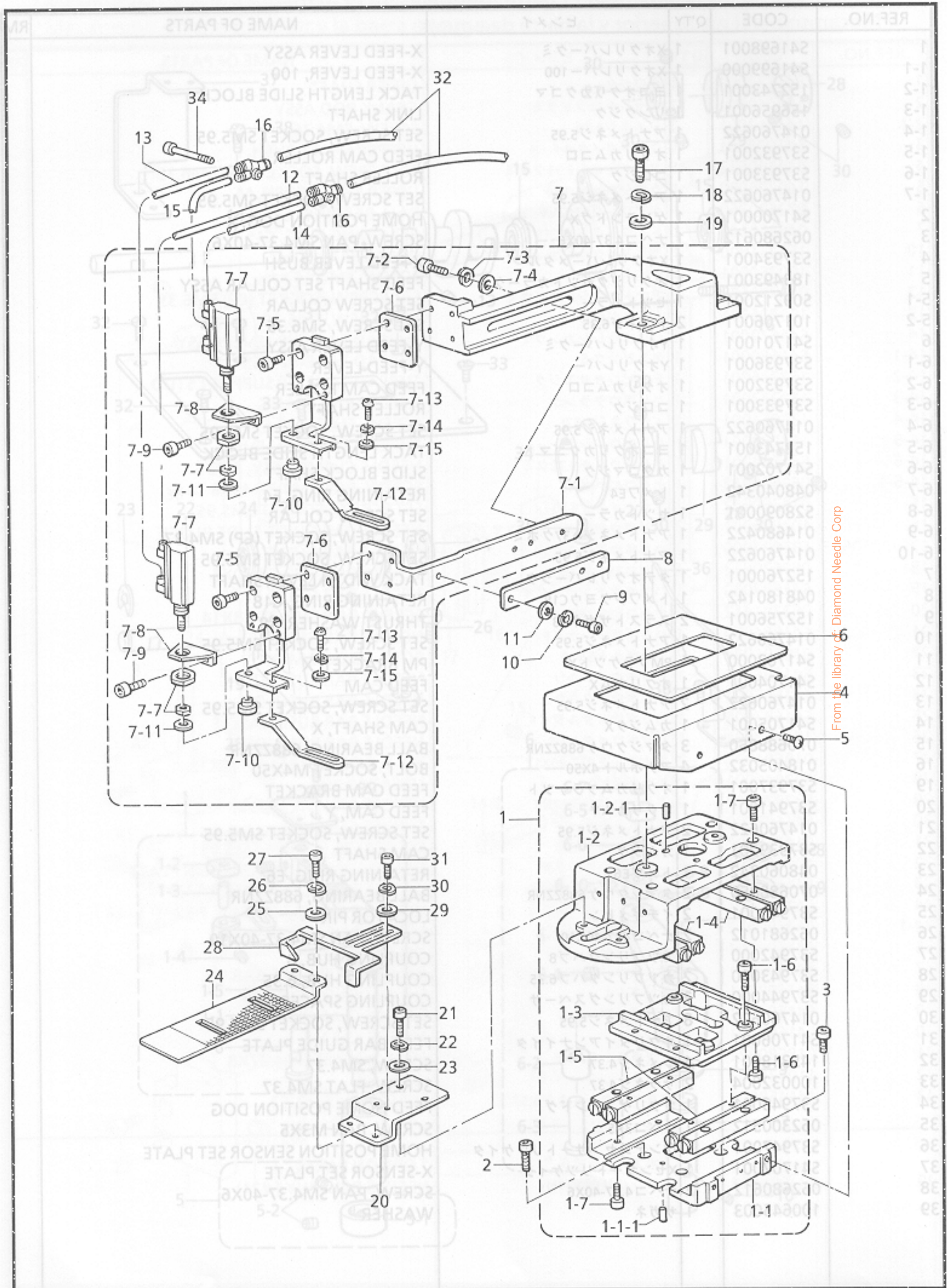

C2. 送り関係 / Feed mechanism / Transportvorrichtung / Mécanisme de l'entraînement  
/ Mecanismo de la alimentación

Mechanism of the feed

REF.NO.	CODE	Q'TY	ヒンメイ	NAME OF PARTS	RM
1	S41777001	1	オクリダイクミ	FEED BAR ASSY	
1-1	S41778001	1	オクリドダイクミ	FEED BASE ASSY	
1-1-1	S16431001	2	5X11ジク	STUD, 5X11	
1-2	S41780001	1	オクリダイXクミ	FEED BAR ASSY, X	
1-2-1	S16431001	2	5X11ジク	STUD, 5X11	
1-3	S41782001	1	オクリダイY	FEED BAR, Y	
1-4	S41783000	1	クロスローラX	CROSS ROLLER, X	
1-5	S41784000	1	クロスローラY	CROSS ROLLER, Y	
1-6	018501636	8	アナボルト5X16	BOLT, SOCKET M5X16	
1-7	018501036	8	アナボルト5X10	BOLT, SOCKET M5X10	
2	018500836	3	アナボルト5X8	BOLT, SOCKET M5X8	
3	018500636	1	アナボルト5X6	BOLT, SOCKET M5X6	
4	S41785001	1	オクリカバー	FEED COVER	
5	008400604	2	+トラスコ4X6	SCREW, TRUSS M4X6	
6	S41786000	1	オクリカザリイタ	FEED DECORATIVE PLATE	
7	S41787001	1	オサエウデクミA	WORK CLAMP ARM ASSY, A	
7-1	S41789001	1	オサエゼンゴウデ	WORK CLAMP SET ARM	
7-2	018401636	2	アナボルト4X16	BOLT, SOCKET M4X16	
7-3	028040246	2	バネザガネ2-4	WASHER, SPRING 2-4	
7-4	025040236	2	ヒラザガネチユウ4	WASHER, PLAIN M 4	
7-5	018401036	8	アナボルト4X10	BOLT, SOCKET M4X10	
7-6	S41791000	2	スパーサ	SPACER	
7-7	S41792000	2	シリンダクミ	CYLINDER ASSY	
7-8	S41794001	2	フートA	FOOT, A	
7-9	018400836	4	アナボルト4X8	BOLT, SOCKET M4X8	
7-10	S14974001	2	オサエナツト	PRESSER NUT	
7-11	102707002	2	ザガネ	WASHER, PLAIN 4	
7-12	S41796001	2	オサエ	WORK CLAMP	
7-13	S21716001	2	ボタンヘッドネジ4X10	SCREW, M4X10	
7-14	028040246	2	バネザガネ2-4	WASHER, SPRING 2-4	
7-15	102707002	2	ザガネ	WASHER, PLAIN 4	
8	S41801001	1	オクリホキヨウイタ	FEED PROTECTED PLATE	
9	018401036	2	アナボルト4X10	BOLT, SOCKET M4X10	
10	028040246	2	バネザガネ2-4	WASHER, SPRING 2-4	
11	025040236	2	ヒラザガネチユウ4	WASHER, PLAIN M 4	
12	S18387007	1	エアチューブ	AIR TUBE, (L = 370)	
13	S08125000	1	エアホース4-S1	AIR TUBE, 4-S1 (L = 410)	
14	S41635000	1	エアホース0425S0318	AIR TUBE, 0425S (L = 310)	
15	S41935000	1	エアホース0425S0358	AIR TUBE, 0425S (L = 350)	
16	S19557000	2	コガタユニオンワイ4	MINIATURE UNION, Y4	
17	018501636	2	アナボルト5X16	BOLT, SOCKET M5X16	
18	028050246	2	バネザガネ2-5	WASHER, SPRING 2-5	
19	025050236	2	ヒラザガネチユウ5	WASHER, PLAIN M 5	
20	S41802001	1	オクリイタダイ	FEED PLATE BASE	
21	018401036	2	アナボルト4X10	BOLT, SOCKET M4X10	
22	028040242	2	バネザガネ2-4	WASHER, SPRING 2-4	
23	025040136	2	ヒラザガネシヨウ4	WASHER, PLAIN S 4	
24	S41 ※ 000	1	オクリイタ	FEED PLATE	
25	S19543001	2	ザガネ	WASHER	
26	028040246	2	バネザガネ2-4	WASHER, SPRING 2-4	
27	018400636	2	アナボルト4X6	BOLT, SOCKET M4X6	
28	S41804001	1	ミゴロジヨウギ	RULLER	
29	025040236	2	ヒラザガネチユウ4	WASHER, PLAIN M 4	
30	028040246	2	バネザガネ2-4	WASHER, SPRING 2-4	
31	018400836	2	アナボルト4X8	BOLT, SOCKET M4X8	
32	S41943000	2	エアホース0425S1458	AIR TUBE, 0425S (L = 1450)	
34	S24949000	1	CQ2ボルトM3X45	CQ2 BOLT, M3X45	
129	S41527001	1	センサートリツケイタ	SENSOR SETTING PLATE	
130	0A5401006	1	ベサクミ4X10DB	SCREW, PAN (S/P WASHER) M4X10	

From the library of: Diamond Needle Corp

D1. フィーダー関係 / Feeder mechanism / Knopfsortierer / Tricur de boutons  
 / Mecanismo de botones

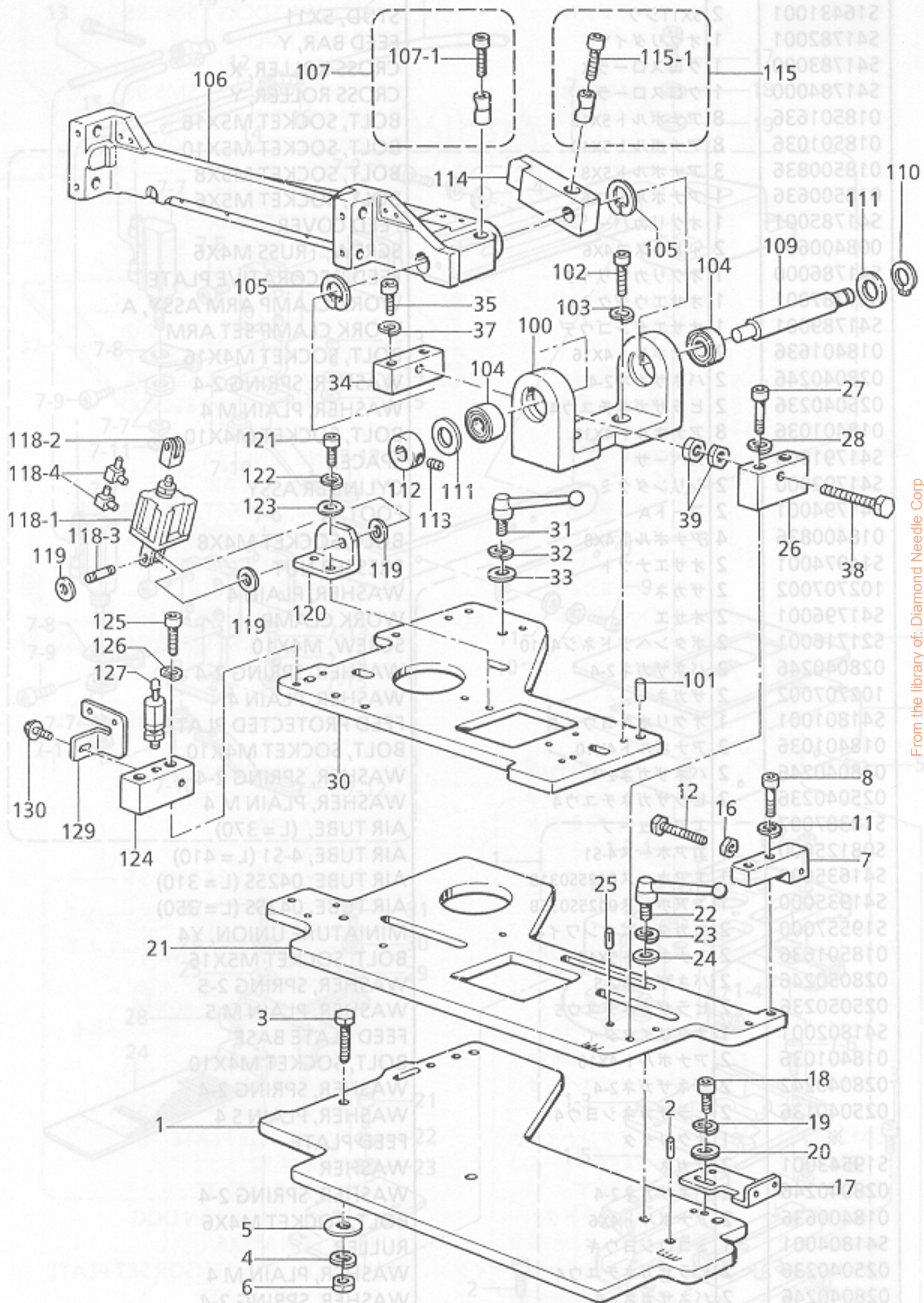

From the library of: Diamond Needle Corp

D1. フィーダー関係 / Feeder mechanism / Knopfsortierer / Tricur de boutons / Mecanismo de botones

REF.NO.	CODE	Q'TY	ヒンメイ	NAME OF PARTS	RM
1	S41511001	1	フィダーベースイタ	FEEDER BASE PLATE	
2	118550001	2	ミゾツキピン	DOWEL PIN	
3	017086006	3	ボルト 8X60	BOLT, M8X60	
4	028080246	3	バネザガネ 2-8	WASHER, SPRING 2-8	
5	213650001	3	ワ 2.3X8.5X38ST	WASHER, 2.3X8.5X38ST	
6	021080206	3	2シユナツト 8	NUT, 2 M8	
7	S41512001	1	イチギメブロツク C	POSITIONING BLOCK, C	
8	018062036	2	アナボルト 6X20	BOLT, SOCKET M6X20	
11	028060246	2	バネザガネ 2-6	WASHER, SPRING 2-6	
12	S24089001	1	ボルト 8X50	BOLT, M8X50	
16	021080206	1	2シユナツト 8	NUT, 2 M8	
17	S41960001	1	センサートリツケイタ	SENSOR SETTING PLATE	
18	018401036	2	アナボルト 4X10	BOLT, SOCKET M4X10	
19	028040246	2	バネザガネ 2-4	WASHER, SPRING 2-4	
20	025040236	2	ヒラザガネチユウ 4	WASHER, PLAIN M 4	
21	S41513001	1	フィダータイヒイタ	FEEDER TAKE SHELTER PLATE	
22	S16122000	1	クランプレバー	CLAMP LEVER	
23	028080242	1	バネザガネ 2-8	WASHER, SPRING 2-8	
24	159947001	1	ストツプレバーザガネ	WASHER, PLAIN 8	
25	118550001	2	ミゾツキピン	DOWEL PIN	
26	S41514001	1	イチギメブロツク B	POSITIONING BLOCK, B	
27	018063036	2	アナボルト 6X30	BOLT, SOCKET M6X30	
28	028060246	2	バネザガネ 2-6	WASHER, SPRING 2-6	
30	S41515001	1	ハバチヨウセイイタ	LOOP WIDTH ADJUSTING PLATE	
31	S16122000	1	クランプレバー	CLAMP LEVER	
32	028080242	1	バネザガネ 2-8	WASHER, SPRING 2-8	
33	159947001	1	ストツプレバーザガネ	WASHER, PLAIN 8	
34	S41516001	1	イチギメブロツク A	POSITIONING BLOCK, A	
35	018063036	2	アナボルト 6X30	BOLT, SOCKET M6X30	
37	028060246	2	バネザガネ 2-6	WASHER, SPRING 2-6	
38	S24250001	1	ボルト 8X90	BOLT, M8X90	
39	021080206	2	2シユナツト 8	NUT, 2 M8	
100	S41517000	1	シリンダーウデブラケット	CYLINDER ARM BRACKET	
101	156958001	2	スイハイオクリウデジク	FEED ROCK ARM STUD	
102	018062036	2	アナボルト 6X20	BOLT, SOCKET M6X20	
103	028060246	2	バネザガネ 2-6	WASHER, SPRING 2-6	
104	076002800	2	タマジクウケ 6002ZZ	BALL BEARING, 6002ZZ	
105	048320242	2	トメワアナヨウ C32	RETAINING RING, C32	
106	S41518000	1	クドウシリンダーウデ	DRIVING CYLINDER ARM	
107	S09132001	1	ピンチスリーブクミ	PINCH SLEEVE ASSY	
107-1	018063022	1	アナボルト 6X30	BOLT, SOCKET M6X30	
109	S41519001	1	シリンダトリツケウデジク	CYLINDER SETTING ARM SHAFT	
110	048150142	1	トメワジクヨウ C15	RETAINING RING, C15	
111	116920001	2	オクリジクスラストリング	THRUST RING	
112	S12134001	1	ナカオサエカラー	INNER PRESSER COLLAR	
113	012060636	2	アナヒラ 6X6	SET SCREW, SOCKET (FT) M6X6	
114	S41520001	1	シリンダレンカン	CYLINDER CONNECTING ROD	
115	S09132001	1	ピンチスリーブクミ	PINCH SLEEVE ASSY	
115-1	152725000	1	ピンチスリーブ	PINCH SLEEVE	
115-2	018063022	1	アナボルト 6X30	BOLT, SOCKET M6X30	
118	S41521000	1	シリンダー 25X10クミ	CYLINDER ASSY, 25X10	
118-1	S41522000	1	シリンダー 25X10	CYLINDER, 25X10	
118-2	S41523000	1	2ヤマナツクルジョイント	KNUKLE JOINT	
118-3	S41524000	2	ナツクルヨウピン	PIN	
118-4	S12150000	2	ホースエルボ M-5HL-4	TUBE ELBOW, M-5HL-4	
119	025100236	2	ヒラザガネチユウ 10	WASHER, PLAIN M 10	
120	S41525001	1	シリンダササエ	CYLINDER SUPPORT	
121	018061636	2	アナボルト 6X16	BOLT, SOCKET M6X16	
122	028060246	2	バネザガネ 2-6	WASHER, SPRING 2-6	
123	025060236	2	ヒラザガネチユウ 6	WASHER, PLAIN M 6	
124	S41526001	1	ストツバーダイ	STOPPER BASE	
125	018061636	2	アナボルト 6X16	BOLT, SOCKET M6X16	
126	028060246	2	バネザガネ 2-6	WASHER, SPRING 2-6	
127	S14874000	1	シヨツクアブソーバ	SHOCK ABSORBER	
129	S41527001	1	センサートリツケイタ	SENSOR SETTING PLATE	
130	0A5401006	1	ナベザクミ 4X10DB	SCREW, PAN (S/P WASHER) M4X10	

From the library of: Diamond Needle Corp

D2. フィーダー関係 / Feeder mechanism / Knopfsortierer / Tricur de boutons / Mecanismo de botones

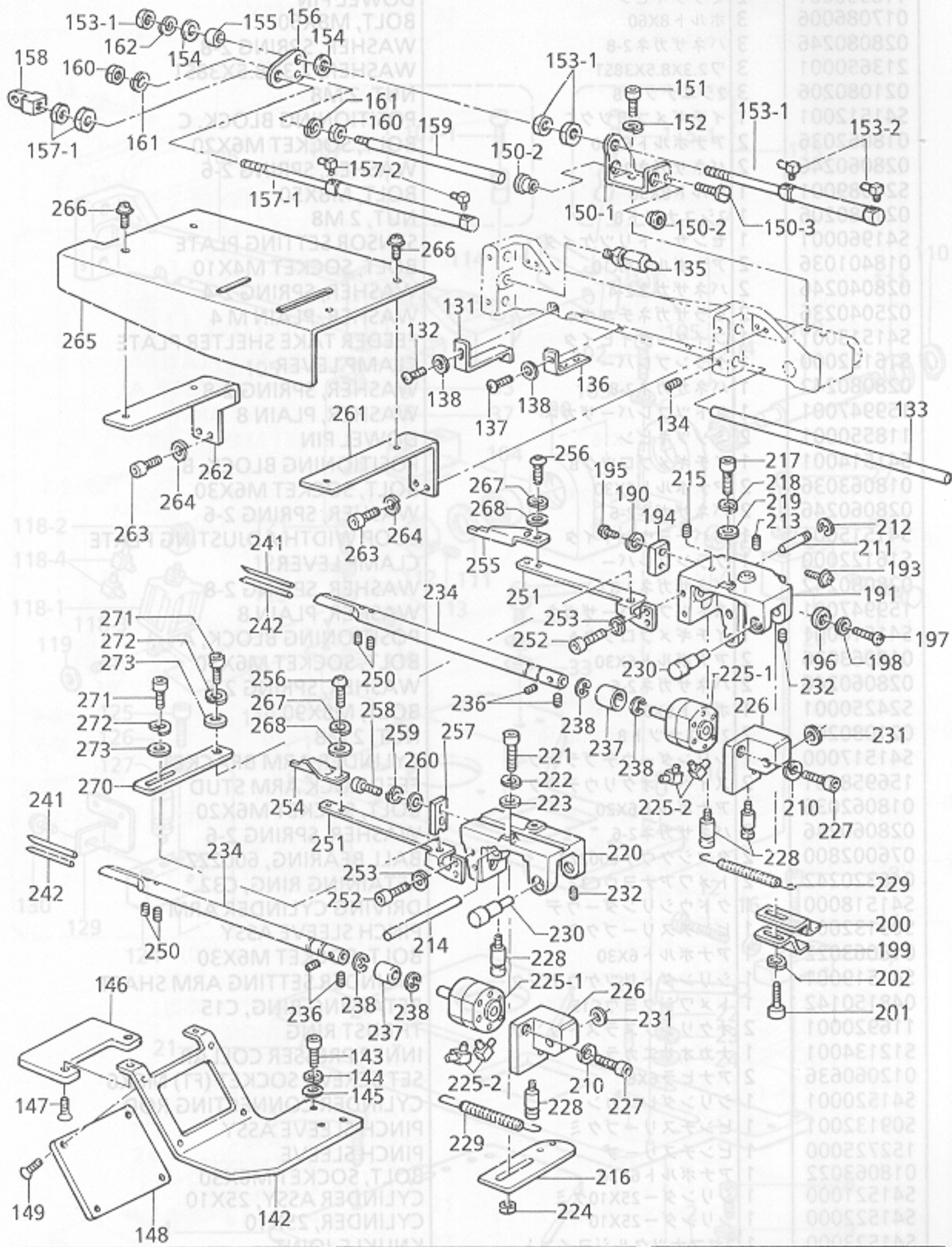

From the library of: Diamond Needle Corp

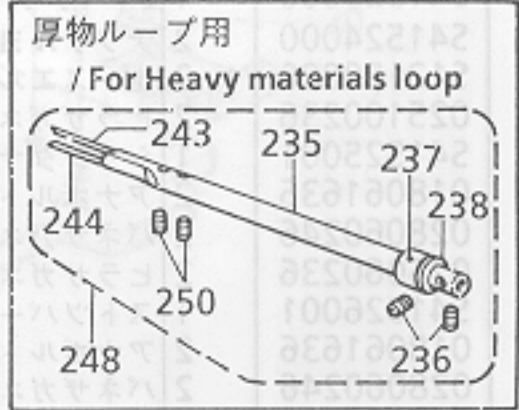
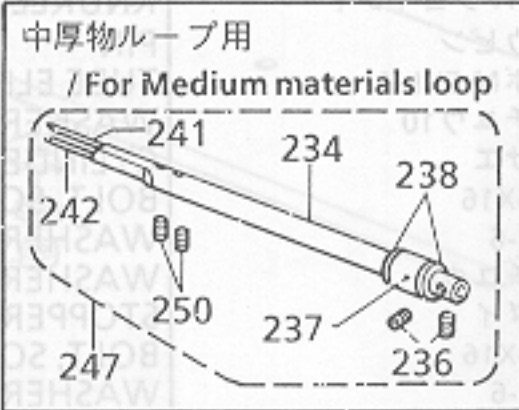

D2. フィーダー関係 / Feeder mechanism / Knopfsortierer / Tricur de boutons / Mecanismo de botones

REF.NO.	CODE	Q'TY	ヒンメイ	NAME OF PARTS	RM
131	S41528001	1	センサードグ	SENSOR DOG	
132	060400816	1	バインド4X8	SCREW, BIND M4X8	
133	S41529001	2	ホークユニットアンナイジク	FORK UNIT GUIDE SHAFT	
134	012500536	4	アナヒラ5X5	SET SCREW, SOCKET (FT) M5X5	
135	S14874000	1	シヨツクアブソーバ	SHOCK ABSORBER	
136	S41530001	4	センサートリツケイタ	SENSOR SETTING PLATE	
137	060400816	4	バインド4X8	SCREW, BIND M4X8	
138	025040236	5	ヒラザガネチユウ4	WASHER, PLAIN M 4	
142	S41912001	1	ホークガードササエ	FORK GUARD SUPPORT	
143	018061436	2	アナボルト6X14	BOLT, SOCKET M6X14	
144	028060246	2	バネザガネ2-6	WASHER, SPRING 2-6	
145	025060236	2	ヒラザガネチユウ6	WASHER, PLAIN M 6	
146	S41913000	1	ホークガード1	FORK GUARD, 1	
147	004400814	2	+サラコ4X8	SCREW, FLAT M4X8	
148	S41914000	1	ホークガード2	FORK GUARD, 2	
149	S31258001	1	+サラコ4X6	SCREW, FLAT M4X8	
150	S41531001	1	シリンダードダイクミ	CYLINDER BASE ASSY	
150-1	S41532001	1	シリンダードダイ	CYLINDER BASE	
150-2	S41533000	2	フランジブツシュ	FLANGE BUSHING	
150-3	060400616	2	バインドM4X6	SCREW, BIND M4X6	
151	018061436	2	アナボルト6X14	BOLT, SOCKET M6X14	
152	028060246	2	バネザガネ2-6	WASHER, SPRING 2-6	
153	S41534000	1	シリンダ16X40クミ	CYLINDER ASSY, 16X40	
153-1	S41535000	1	シリンダ16X40	CYLINDER, 16X40	
153-2	S12150000	2	ホースエルボM-5HL-4	TUBE ELBOW, M-5HL-4	
154	146354001	2	ザガネ	WASHER, PLAIN 5	
155	153218001	1	シタイトサバキカラー	LOWER THREAD RETAINER COLLAR	
156	S41536001	1	シリンダレンケツイタ	CYLINDER CONNECTING PLATE	
157	S41537000	1	シリンダ16X125クミ	CYLINDER ASSY, 16X125	
157-1	S41538000	1	シリンダ16X125	CYLINDER, 16X125	
157-2	S12150000	2	ホースエルボM-5HL-4	TUBE ELBOW, M-5HL-4	
158	S37454000	1	1ヤマナツクルジョイント	KNUCLE JOINT	
159	S41539001	1	ガイドジク	GUIDE SHAFT	
160	021500216	2	2シユナツト5	NUT, 2 M5	
161	028050246	2	バネザガネ2-5	WASHER, SPRING 2-5	
162	028050246	1	バネザガネ2-5	WASHER, SPRING 2-5	
190	028030246	2	バネザガネ2-3	WASHER, SPRING 2-3	
191	S41540000	1	ホークブラケットR	FORK BRACKET, R	
192	S12004000	4	リニアブツシュ	LINEAR BUSH	
193	0A5400806	2	+ナベザクミ4X8DB	SCREW, PAN (S/P WASHER) M4X8	
194	S23653001	1	スライドダイストツバ	SLIDE BASE STOPPER	
195	062300502	2	ナベコ3X5	SCREW, PAN M3X5	
196	S12054000	1	クツシヨン	CUSHION	
197	062401016	1	ナベコ4X10	SCREW, PAN M4X10	
198	025040236	1	ヒラザガネチユウ4	WASHER, PLAIN M 4	
199	S41541001	1	ホークイチケンシユツドグ	FORK POSITION DETECTOR DOG	
200	S41630001	1	ホークイチケンシユツドグ2	FORK POSITION DETECTOR DOG, 2	
201	018401036	2	アナボルト4X10	BOLT, SOCKET M4X10	
202	028040246	2	バネザガネ2-4	WASHER, SPRING 2-4	
210	028040246	2	バネザガネ2-4	WASHER, SPRING 2-4	
211	S41542001	1	ピン	PIN	
212	048050142	1	トメワジクヨウC5	RETAINING RING, C5	
213	012400436	2	アナヒラ4X4	SET SCREW, SOCKET (FT) M4X4	
214	S41544001	1	アンナイジク	GUIDE SHAFT	
215	012060636	1	アナヒラ6X6	SET SCREW, SOCKET (FT) M6X6	
216	S41545001	1	ホークスライドイタ	FORK SLIDE PLATE	
217	018501236	2	アナボルト5X12	BOLT, SOCKET M5X12	
218	028050246	2	バネザガネ2-5	WASHER, SPRING 2-5	
219	026050136	2	ヒラザガネコガタ5	WASHER, PLAIN S 5	

From the library of: Diamond Needle Corp



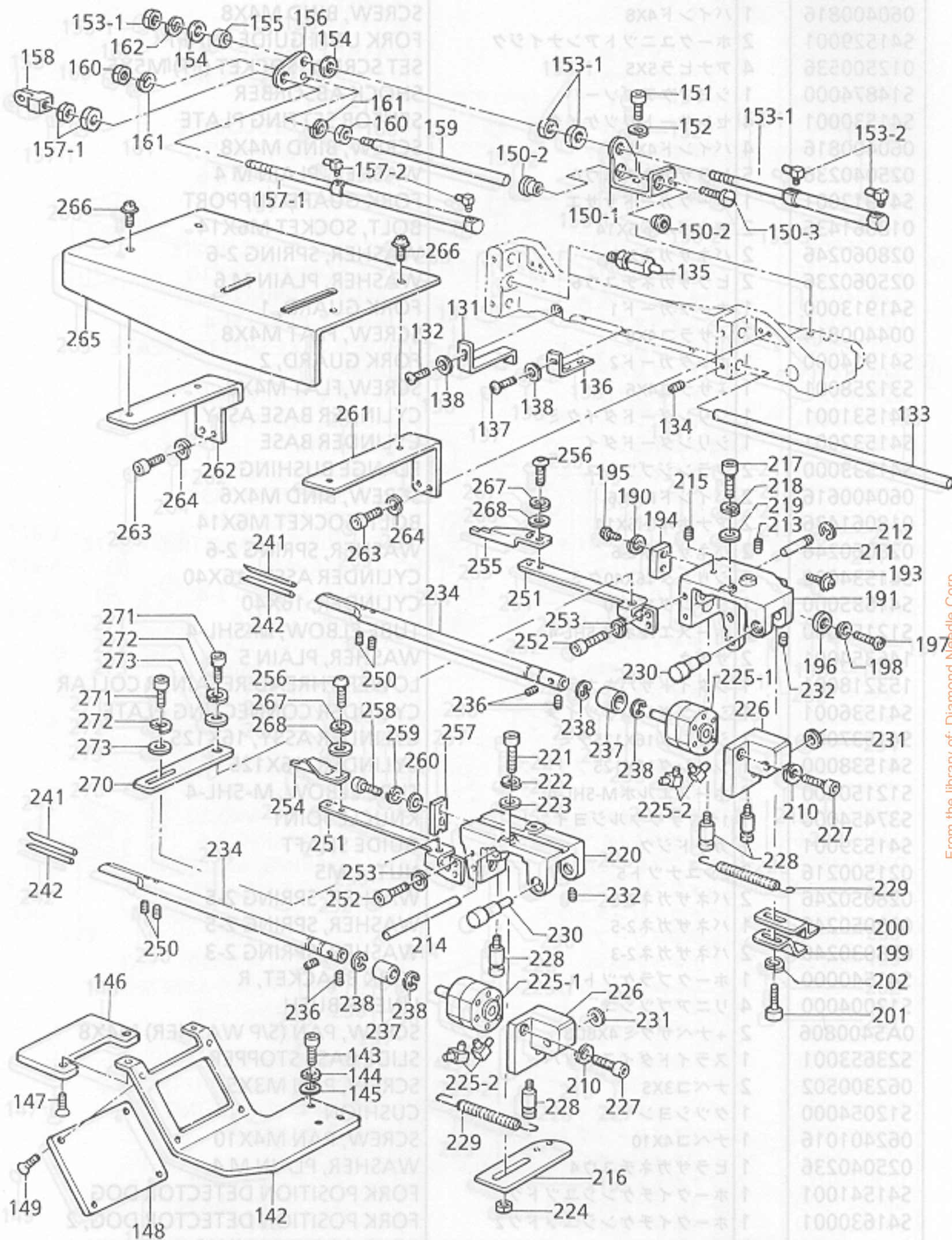

From the library of: Diamond Needle Corp

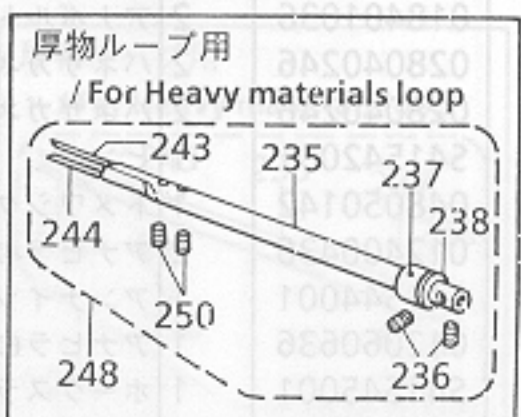
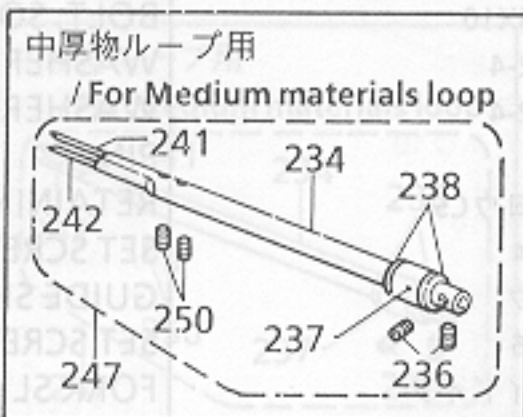

D2. フィーダー関係 / Feeder mechanism / Knopfsortierer / Tricur de boutons / Mecanismo de botones

REF.NO.	CODE	Q'TY	ヒンメイ	NAME OF PARTS	RM
220	S41543000	1	ホークブラケットF	FORK BRACKET, F	
221	018501636	2	アナボルト5X16	BOLT, SOCKET M5X16	
222	028050246	2	バネザガネ2-5	WASHER, SPRING 2-5	
223	026050136	2	ヒラザガネコガタ5	WASHER, PLAIN S 5	
224	021500216	2	2シユナツト5	NUT, 2 M5	
225	S41548000	2	ロータリーシリンダ20クミ	ROTARY CYLINDER ASSY, 20	
225-1	S41549000	2	ロータリーシリンダ	ROTARY CYLINDER	
225-2	S12150000	4	ホースエルボM-5HL-4	TUBE ELBOW, M-5HL-4	
226	S41550000	2	シリンダトリツケタイ	CYLINDER SETTING BASE	
227	018402536	4	アナボルト4X25	BOLT, SOCKET M4X25	
228	S13330001	4	バネカケ	SPRING HOOK	
229	S16422001	2	ヒキバネ	SPRING	
230	S41551001	2	ロータリーシリンダジク	ROTARY CYLINDER SHAFT	
231	110367001	2	ザガネ	WASHER, PLAIN SPECIAL 8	
232	012500536	2	アナヒラ5X5	SET SCREW, SOCKET (FT) M5X5	
251	S41556101	2	ユルメオサエトリツケイタ	LOOSEN LOOP PRESSER SET PLATE	
252	018501036	4	アナボルト5X10	BOLT, SOCKET M5X10	
253	028050246	4	バネザガネ2-5	WASHER, SPRING 2-5	
254	S41557001	1	ユルメオサエF	LOOSEN LOOP PRESSER FOOT, F	
255	S41558001	1	ユルメオサエB	LOOSEN LOOP PRESSER FOOT, B	
256	S21715001	4	ボタンヘッドネジ4X6	SCREW, M4X6	
257	S41559000	1	ホークカナグストツバ	FORK STOPPER	
258	018401636	2	アナボルト4X16	BOLT, SOCKET M4X16	
259	028040246	2	バネザガネ2-4	WASHER, SPRING 2-4	
260	025040236	2	ヒラザガネチユウ4	WASHER, PLAIN M 4	
261	S41560001	1	カバートリツケイタA	COVER SETTING PLATE, A	
262	S41561001	1	カバートリツケイタB	COVER SETTING PLATE, B	
263	018401036	4	アナボルト4X10	BOLT, SOCKET M4X10	
264	028040246	4	バネザガネ2-4	WASHER, SPRING 2-4	
265	S41563109	1	フィダーカバー	FEEDER COVER	
266	0A5400806	4	ナベザクミ4X8DB	SCREW, PAN (S/P WASHER) M4X8	
267	028040246	4	バネザガネ2-4	WASHER, SPRING 2-4	
268	025040236	4	ヒラザガネチユウ4	WASHER, PLAIN M 4	
270	S43634001	1	レンケツイタ	CONNECTING PLATE	
271	018400836	2	アナボルト4X8	BOLT SOCKET, M4X8	
272	028040246	2	バネザガネ2-4	WASHER, SPRING 2-4	
273	025040236	2	ヒラザガネチユウ4	WASHER, PLAIN M 4	
<hr/>					
234	028040246	4	<中厚物ループ用>	<For Medium materials loop>	
236	S41622001	2	ホークカナグB	FORK, B	
237	012400436	4	アナヒラ4X4	SET SCREW, SOCKET (FT) M4X4	
238	S41553000	2	ホークブツシュ	FORK BUSHING	
241	048120142	4	トメワジクヨウC12	RETAINING RING, C12	
242	S41623001	2	ホークジク1.8L	FORK SHAFT, 1.8L	
242	S41624001	2	ホークジク1.8S	FORK SHAFT, 1.8S	
250	012400436	4	アナヒラ4X4	SET SCREW, SOCKET (FT) M4X4	
<hr/>					
233	S41552001	2	"オプション部品" <薄物ループ用>	"OPTION PARTS" <For Thin materials loop>	
241	S41623001	2	ホークカナグA	FORK, A	
242	S41624001	2	<薄・中厚物ループ用>	<For Thin & medium materials loop>	
241	S41623001	2	ホークジク1.8L	FORK SHAFT, 1.8L	
242	S41624001	2	ホークジク1.8S	FORK SHAFT, 1.8S	
235	S41625001	2	<厚物ループ用>	<For Heavy materials loop>	
243	S41626001	2	ホークカナグC	FORK, C	
244	S41627001	2	ホークジク2.0L	FORK SHAFT, 2.0L	
244	S41627001	2	ホークジク2.0S	FORK SHAFT, 2.0S	
246	S41931001	1	<薄物ループ用>	<For Heavy materials loop>	
246	S41931001	1	ホークカナグAクミ	FORK ASSY, A	
247	012400436	2	<中厚物ループ用>	<For Medium materials loop>	
247	S41932001	1	ホークカナグBクミ	FORK ASSY, B	
248	155103001	2	<厚物ループ用>	<For Heavy materials loop>	
248	S41933001	1	ホークカナグCクミ	FORK ASSY, C	

From the library of: Diamond Needle Corp

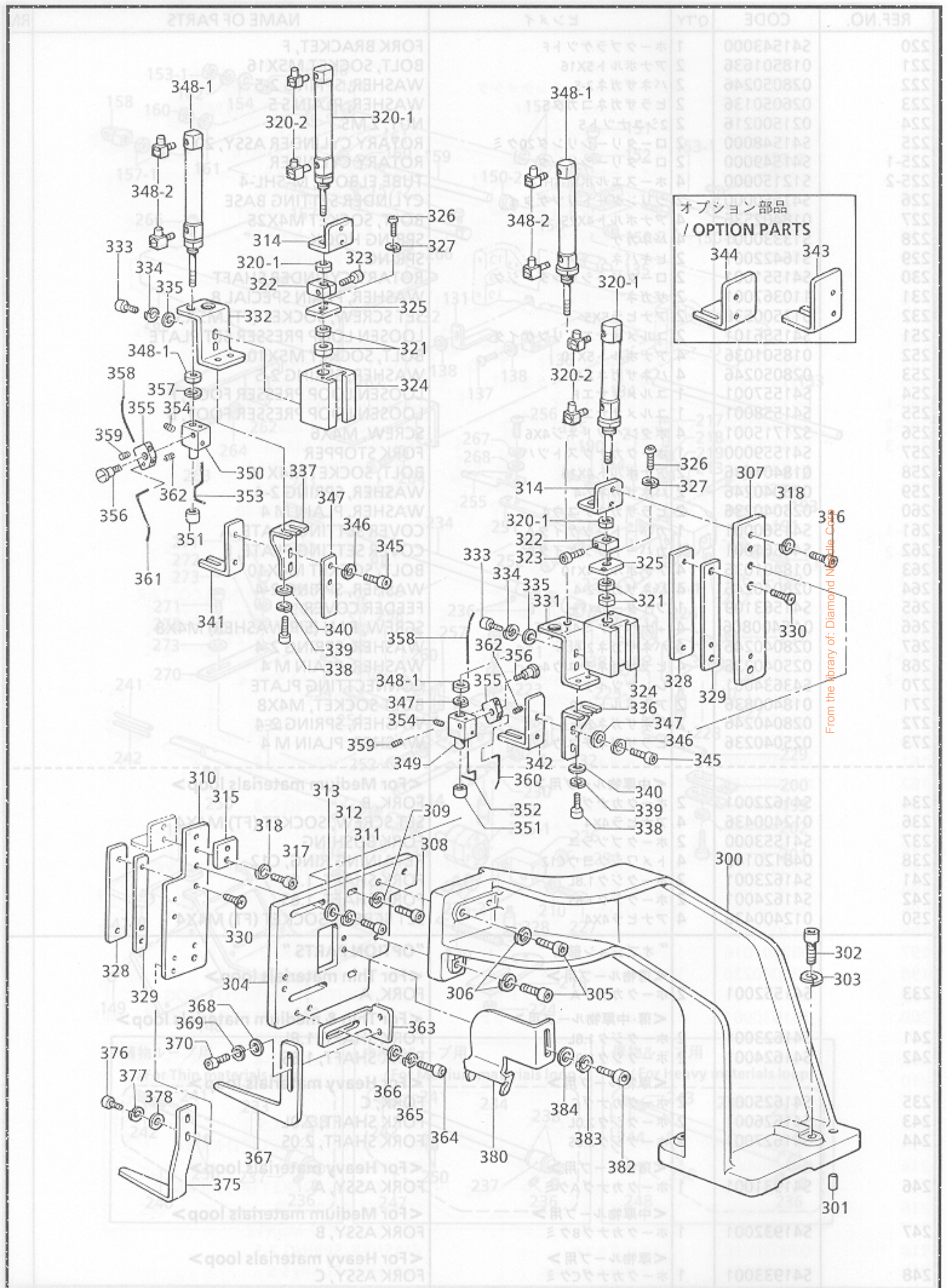

D3. フィーダー関係 / Feeder mechanism / Knopfsortierer / Tricur de boutons / Mecanismo de botones

REF.NO.	CODE	Q'TY	ヒンメイ	NAME OF PARTS	RM
300	S41562009	1	ループユニットダイ	LOOP UNIT BASE	
301	156958001	2	スイヘイオクリウデジク	FEED ROCK ARM STUD	
302	018062536	3	アナホルト6X25	BOLT, SOCKET M6X25	
303	028060246	3	バネザガネ2-6	WASHER, SPRING 2-6	
304	S41564001	1	オリユニットトリツケイタ	PRESSER UNIT SETTING PLATE	
305	018051636	3	アナホルト5X16	BOLT, SOCKET M5X16	
306	028050246	3	バネザガネ2-5	WASHER, SPRING 2-5	
307	S41565001	1	スライダーベースB	SLIDER BASE, B	
308	018401036	2	アナホルト4X10	BOLT, SOCKET M4X10	
309	028040246	2	バネザガネ2-4	WASHER, SPRING 2-4	
310	S41566001	1	スライダベースF	SLIDER BASE, F	
311	018401036	2	アナホルト4X10	BOLT, SOCKET M4X10	
312	028040246	2	バネザガネ2-4	WASHER, SPRING 2-4	
313	158722002	2	ザガネ4.2	WASHER, PLAIN 4.2	
314	S41567001	2	シリンダートリツケイタA	CYLINDER SETTING PLATE, A	
315	S33896001	1	スイコミクチレンケツイタ	SUCTION OPENING CONECTING PLAT E	
316	018400836	2	アナホルト4X8	BOLT, SOCKET M4X8	
317	018401036	2	アナホルト4X10	BOLT, SOCKET M4X10	
318	028040246	4	バネザガネ2-4	WASHER, SPRING 2-4	
320	S41568000	2	シリンダー10X45クミ	CYLINDER ASSY, 10X45	
320-1	S41569000	2	シリンダー10X45	CYLINDER, 10X45	
320-2	S12150000	2	ホースエルボM-5HL-4	TUBE ELBOW, M-5HL-4	
321	021400316	4	3シユナツト4	NUT, 3 M4	
322	S41570001	2	シリンダーストツバ	CYLINDER STOPPER	
323	018400836	2	アナホルト4X8	BOLT, SOCKET M4X8	
324	S41571001	2	スライダブラケット	SLIDER BRACKET	
325	S41572001	2	ロツドオサエイタ	ROD PRESSER PLATE	
326	060400816	4	バインド4X8	SCREW, BIND M4X8	
327	028040246	4	バネザガネ2-4	WASHER, SPRING 2-4	
328	S41573001	2	スライダガイド	SLIDER GUIDE	
329	S41574001	2	スライダガイドスパーサ	SLIDER GUIDE SPACER	
330	004400814	4	+サラコ4X8	SCREW, FLAT M4X8	
331	S41575001	1	シリンダートリツケイタBB	CYLINDER SETTING PLATE, BB	
332	S41576001	1	シリンダートリツケイタBF	CYLINDER SETTING PLATE, BF	
333	018401036	4	アナホルト4X10	BOLT, SOCKET M4X10	
334	028040246	4	バネザガネ2-4	WASHER, SPRING 2-4	
335	025040236	4	ヒラザガネチユウ4	WASHER, PLAIN M 4	
336	S41577001	1	ループオサエトリツケイタB	LOOP PRESSER SETTING PLATE, B	
337	S41578001	1	ループオサエトリツケイタF	LOOP PRESSER SETTING PLATE, F	
338	018400836	4	アナホルト4X8	BOLT, SOCKET M4X8	
339	028040246	4	バネザガネ2-4	WASHER, SPRING 2-4	
340	025040236	4	ヒラザガネチユウ4	WASHER, PLAIN M 4	
341	S41579001	1	ループオサエB	LOOP PRESSER, B	
342	S41580001	1	ループオサエF	LOOP PRESSER, F	
345	018400836	4	アナホルト4X8	BOLT, SOCKET M4X8	
346	028040246	4	バネザガネ2-4	WASHER, SPRING 2-4	
347	S41911001	2	ループワイパー	LOOP WIPER	
348	S41581000	2	シリンダー10X30クミ	CYLINDER ASSY, 10X30	
348-1	S41582000	2	シリンダー10X30	CYLINDER, 10X30	
348-2	S12150000	2	ホースエルボM-5HL-4	TUBE ELBOW, M-5HL-4	
349	S41583001	1	オサエブロックB	PRESSER BLOCK, B	
350	S41584001	1	オサエブロックF	PRESSER BLOCK, F	
351	S05356000	2	ボタンオサエA	BUTTON PRESSER, A	
352	S41585001	1	ループオサエUB	LOOP PRESSER, UB	
353	S41586001	1	ループオサエUF	LOOP PRESSER, UF	
354	012400436	2	アナヒラ4X4	SET SCREW, SOCKET (FT) M4X4	
355	S41587001	2	ハバヨセブロック	WIDTH NARROW BLOCK	
356	155103001	2	ダンネジ3.18	SHOULDER SCREW, SM3.18	
357	028040246	2	バネザガネ2-4	WASHER, SPRING 2-4	

From the library of: Diamond Needle Corp

D3. フィーダー関係 / Feeder mechanism / Knopfsortierer / Tricur de boutons / Mecanismo de botones

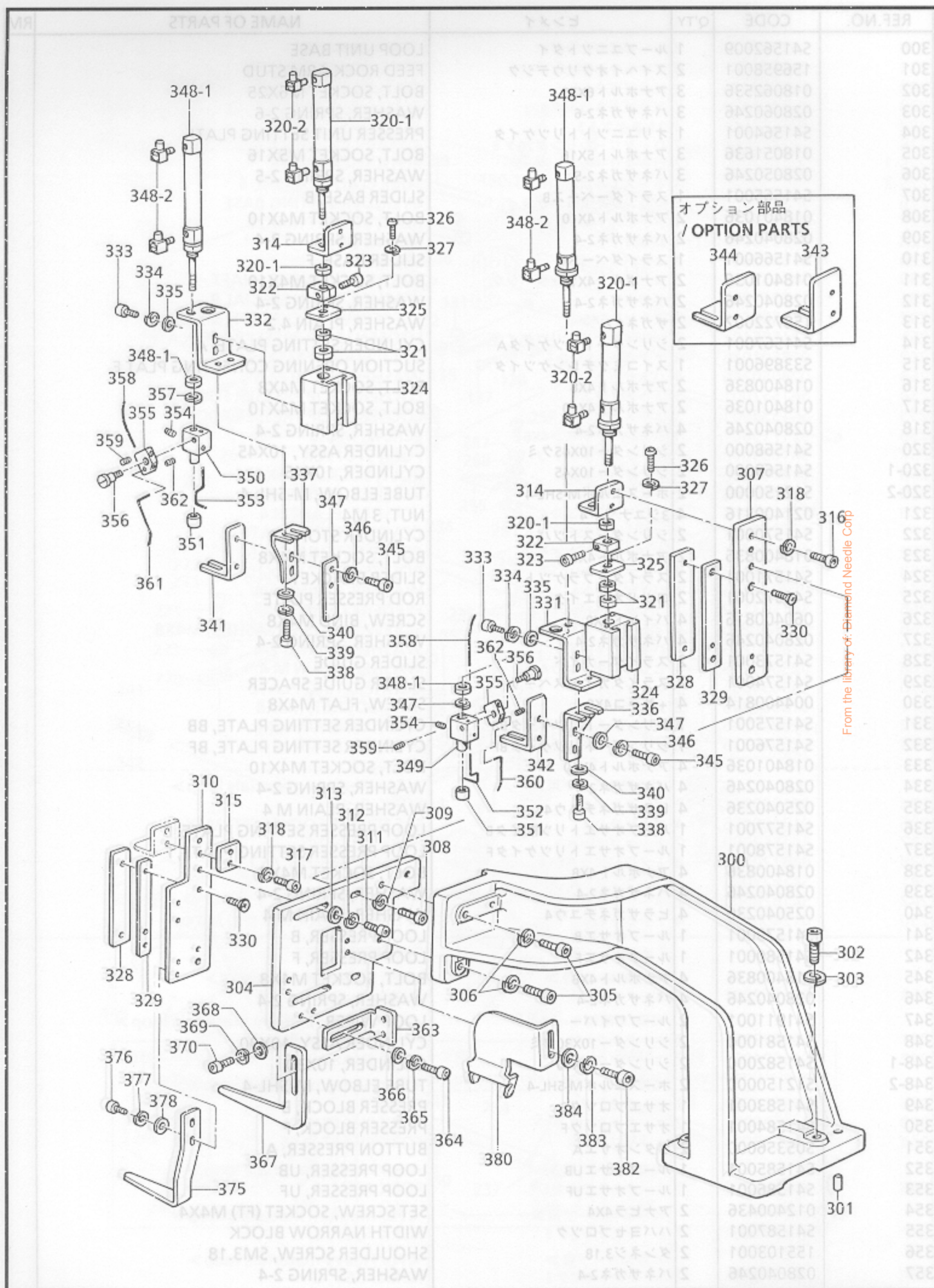

From the library of: Diamond Needle Corp

D3. フィーダー関係 / Feeder mechanism / Knopfsortierer / Tricur de boutons / Mecanismo de botones

REF.NO.	CODE	Q'TY	ヒンメイ	NAME OF PARTS	RM
358	S41588001	2	アンナイバネ	GUIDE SPRING	
359	012400436	2	アナヒラ4X4	SET SCREW, SOCKET (FT) M4X4	
360	S41589001	1	ハバヨセバネB	SPRING, WIDTH NARROW (B)	
361	S41590001	1	ハバヨセバネF	SPRING, WIDTH NARROW (F)	
362	012400436	2	アナヒラ4X4	SET SCREW, SOCKET (FT) M4X4	
363	S41591001	1	ループウカシトリツケイタ	LOOP HOLD SETTING PLATE	
364	018400836	2	アナボルト4X8	BOLT, SOCKET M4X8	
365	028040246	2	バネザガネ2-4	WASHER, SPRING 2-4	
366	025040236	2	ヒラザガネチユウ4	WASHER, PLAIN M 4	
367	S41592001	1	ループウカシイタ	LOOP HOLD PLATE	
368	018400836	2	アナボルト4X8	BOLT, SOCKET M4X8	
369	028040246	2	バネザガネ2-4	WASHER, SPRING 2-4	
370	025040236	2	ヒラザガネチユウ4	WASHER, PLAIN M 4	
375	S41596001	1	ループササエF	LOOP SUPPORT, F	
376	018400636	2	アナボルト4X6	BOLT, SOCKET M4X6	
377	028040246	2	バネザガネ2-4	WASHER, SPRING 2-4	
378	025040236	2	ヒラザガネチユウ4	WASHER, PLAIN M 4	
382	018400836	2	アナボルト4X8	BOLT, SOCKET M4X8	
383	028040246	2	バネザガネ2-4	WASHER, SPRING 2-4	
384	025040236	2	ヒラザガネチユウ4	WASHER, PLAIN M 4	
380	S41604001	1	<針間隔56 mm未満用> ウエガイドイタA	<For Stitch interval Max. 56mm> UPPER GUIDE PLATE, A	
343	S41594001	1	" オプション部品 " ループオサエ70B	" OPTION PARTS " LOOP PRESSER, 70B	
344	S41595001	1	ループオサエ70F	LOOP PRESSER, 70F	
345	028040246	2	バネザガネ2-4	WASHER, SPRING 2-4	
346	025040236	2	ヒラザガネチユウ4	WASHER, PLAIN M 4	
347	S41606000	1	ノブ	KNOB	
348	018401036	2	アナボルト4X10	SOCKET M4X10	
349	028040246	2	バネザガネ2-4	WASHER, SPRING 2-4	
350	025040236	2	ヒラザガネチユウ4	WASHER, PLAIN M 4	
351	S41606000	1	ノブ	KNOB	
352	018401036	2	アナボルト4X10	SOCKET M4X10	
353	028040246	2	バネザガネ2-4	WASHER, SPRING 2-4	
354	025040236	2	ヒラザガネチユウ4	WASHER, PLAIN M 4	
355	S23701101	1	チャンネル	CHANNEL SUPPORT	
356-1	S23702201	1	チャンネル	CHANNEL BASE	
356-2	S41926001	1	チャンネル	CHANNEL, B	
356-3	S41927001	1	チャンネル	CHANNEL, C	
356-4	060300000	4	ネジ	SCREWS M2X4	
356-5	028030246	4	バネザガネ	WASHER, SPRING 2-3	
356-6	105161004	4	ワッシャー	WASHER	
357	018401036	2	アナボルト4X10	SOCKET M4X10	
358	S14946101	1	ギメセンサ	TOUCH SENSOR BASE	
359	018401036	2	アナボルト4X10	BOLT, SOCKET M4X10	
360	028040246	2	バネザガネ2-4	WASHER, SPRING 2-4	
361	025040236	2	ヒラザガネチユウ4	WASHER, PLAIN M 4	
362	S14949101	1	ギメアクチュエータ	TOUCH ACTUATOR	

From the library of: Diamond Needle Corp

D4. フィーダー関係 / Feeder mechanism / Knopfsortierer / Tricur de boutons  
 / Mecanismo de botones

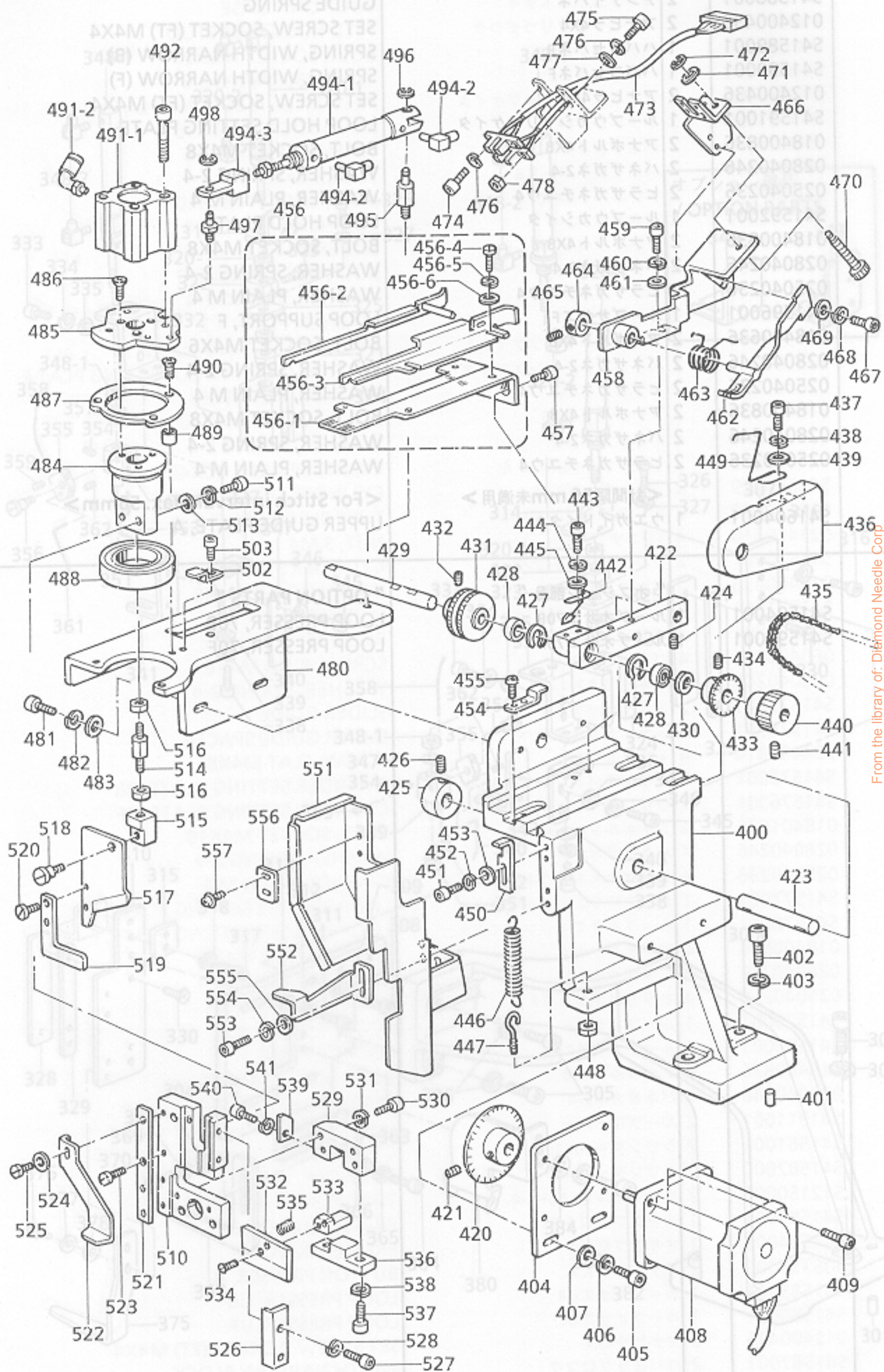

From the library of: Diamond Needle Corp.

D4. フィーダー関係 / Feeder mechanism / Knopfsortierer / Tricur de boutons  
 / Mecanismo de botones

REF.NO.	CODE	Q'TY	ヒンメイ	NAME OF PARTS	RM
400	S41621001	1	ユニットダイ	UNIT BASE	
401	156958001	2	スイハイオクリウデジク	FEED ROCK ARM STUD	
402	018062536	2	アナボルト6X25	BOLT, SOCKET M6X25	
403	028060246	2	バネザガネ2-6	WASHER, SPRING 2-6	
404	S41597001	1	モータトリツケイタ	MOTOR SETTING PLATE	
405	018501236	2	アナボルト5X12	BOLT, SOCKET M5X12	
406	028050246	2	バネザガネ2-5	WASHER, SPRING 2-5	
407	025050236	2	ヒラザガネチユウ5	WASHER, PLAIN M 5	
408	S41598000	1	ハルスモータクミ	PULSE MOTOR ASSY	
409	018401036	4	アナボルト4X10	BOLT, SOCKET M4X10	
420	S41600000	1	スプロケットB	SPROCKET WHEEL, B	
421	012400436	2	アナヒラ4X4	SET SCREW, SOCKET (FT) M4X4	
422	S23696101	1	オクリローラアーム	FEED ROLLER ARM	
423	S14924001	1	ローラシテンジク	ROLLER FULCRUM SHAFT	
424	012400436	1	アナヒラ4X4	SET SCREW, SOCKET (FT) M4X4	
425	S07129001	1	セットカラー	SET SCREW COLLAR	
426	014060622	2	アナトメネジ6X6クボミ	SET SCREW, SOCKET (CP) M6X6	
427	048130242	2	トメワアナヨウC13	RETAINING RING, C13	
428	S14919000	2	タマジクウケ1360ZZ	BALL BEARING, 1360ZZ	
429	S23697001	1	ローラジク	ROLLER SHAFT	
430	S23698001	1	スペーサ	SPACER	
431	S23699101	1	オクリローラ	FEED ROLLER	
432	012400436	2	アナヒラ4X4	SET SCREW, SOCKET (FT) M4X4	
433	S14920000	1	スプロケットA	SPROCKET WHEEL, A	
434	012400436	2	アナヒラ4X4	SET SCREW, SOCKET (FT) M4X4	
435	S41602000	1	チェーン	CHAIN	
436	S41603001	1	スプロケットカバー	SPROCKET WHEEL COVER	
437	018401036	2	アナボルト4X10	BOLT, SOCKET M4X10	
438	028040246	2	バネザガネ2-4	WASHER, SPRING 2-4	
439	025040236	2	ヒラザガネチユウ4	WASHER, PLAIN M 4	
440	S15700009	1	ツマミ	KNOB	
441	014680422	2	アナトメネジ4.37クボミ	SET SCREW, SOCKET (CP) SM4.37	
442	S41606000	1	オクリローラガイド	FEED ROLLER GUIDE	
443	018401036	2	アナボルト4X10	BOLT, SOCKET M4X10	
444	028040246	2	バネザガネ2-4	WASHER, SPRING 2-4	
445	025040236	2	ヒラザガネチユウ4	WASHER, PLAIN M 4	
446	159114001	1	カツタモドシバネ	SPRING	
447	140947002	1	ウワイタチヨウセツネジ	ADJUST SCREW	
448	021400202	2	2シユナツト4	NUT, 2 M4	
449	S41925001	1	ホジヨレバー	SUB LEVER	
450	S14958101	1	ローラストツバ	ROLLER STOPPER	
451	018401036	2	アナボルト4X10	BOLT, SOCKET M4X10	
452	028040246	2	バネザガネ2-4	WASHER, SPRING 2-4	
453	025040236	2	ヒラザガネチユウ4	WASHER, PLAIN M 4	
454	S23701101	1	チャンネルウケ	CHANNEL SUPPORT	
455	062400816	2	ナベコ4X8	SCREW, PAN M4X8	
456	S23702201	1	チャンネルクミ	CHANNEL ASSY	
456-1	S23703101	1	チャンネルベースL	CHANNEL BASE, L	
456-2	S41926001	1	チャンネルB	CHANNEL, B	
456-3	S41927001	1	チャンネルF	CHANNEL, F	
456-4	060300516	4	バインド3X5	SCREW, BIND M3X4	
456-5	028030246	4	バネザガネ2-3	WASHER, SPRING 2-3	
456-6	105161004	4	ザガネ	WASHER	
457	018401036	2	アナボルト4X10	BOLT, SOCKET M4X10	
458	S14946101	1	ツギメセンサダイ	JOINT SENSOR BASE	
459	018401036	2	アナボルト4X10	BOLT, SOCKET M4X10	
460	028040246	2	バネザガネ2-4	WASHER, SPRING 2-4	
461	025040236	2	ヒラザガネチユウ4	WASHER, PLAIN M 4	
462	S14949101	1	ツギメアクチュエータ	JOINT ACTUATOR	

From the library of: Diamond Needle Corp



D4. フィーダー関係 / Feeder mechanism / Knopfsortierer / Tricur de boutons / Mecanismo de botones

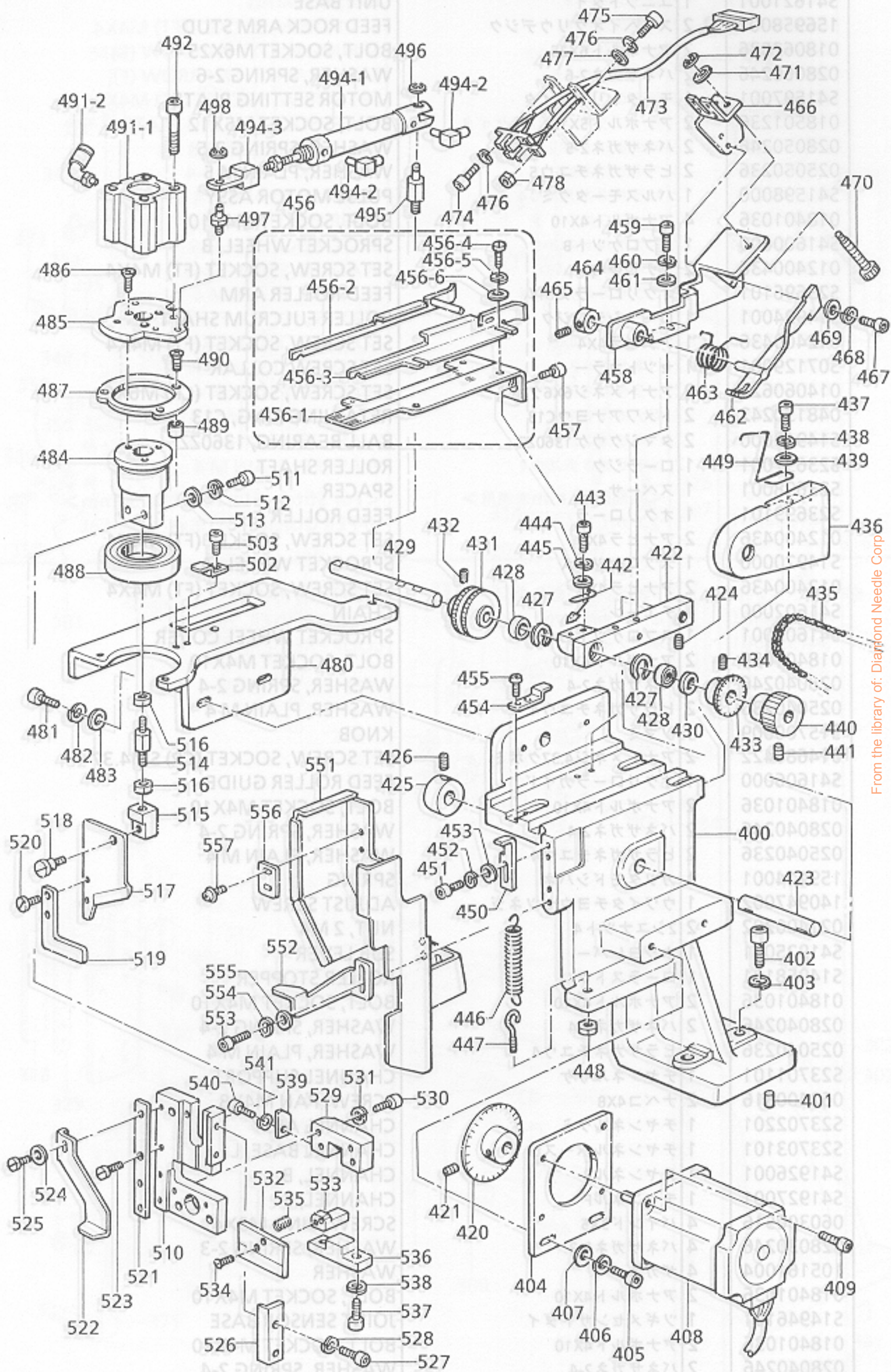

From the library of: Diamond Needle Corp

D4. フィーダー関係 / Feeder mechanism / Knopfsortierer / Tricur de boutons / Mecanismo de botones

REF.NO.	CODE	Q'TY	ヒンメイ	NAME OF PARTS	RM
463	S14950001	1	アクチュエータバネ	SPRING	
464	149864001	1	セツトカラー	SET SCREW COLLAR	
465	100402004	2	トメネジ3.57	SET SCREW, SM3.57	
466	S14947101	1	ツギメセンサダイ	JOINT SENSOR BASE	
467	018400836	2	アナボルト4X8	BOLT, SOCKET M4X8	
468	028040246	2	バネザガネ2-4	WASHER, SPRING 2-4	
469	025040236	2	ヒラザガネチユウ4	WASHER, PLAIN M 4	
470	S14948101	1	チヨウセツジク6	ADJUST SHAFT, 6	
471	025040236	1	ヒラザガネチユウ4	WASHER, PLAIN M 4	
472	048030346	1	トメワE3	RETAINING RING, E3	
473	S40518000	1	ループセンサクミ	LOOP SENSOR ASSY	
474	018300636	2	アナボルト3X6	BOLT, SOCKET M3X6	
475	018301236	2	アナボルト3X12	BOLT, SOCKET M3X12	
476	028030246	4	バネザガネ2-3	WASHER, SPRING 2-3	
477	025030236	2	ヒラザガネチユウ3	WASHER, PLAIN M 3	
478	021300103	2	ナツト1シユ3	NUT, 1 M3	
480	S41620009	1	カッタユニットダイ	KNIFE UNIT BASE	
481	018501636	2	アナボルト5X16	BOLT, SOCKET M5X16	
482	028050246	2	バネザガネ2-5	WASHER, SPRING 2-5	
483	025050236	2	ヒラザガネチユウ5	WASHER, PLAIN M 5	
484	S41607001	1	メスカイテンダイ	KNIFE ROTARY BASE	
485	S41608001	1	メスカイテンダイ2	KNIFE ROTARY BASE, 2	
486	004400814	3	+サラコ4X8	SCREW, FLAT M4X8	
487	S41618001	1	ベアリングオサエ	BEARING PRESSER	
488	076906800	1	タマジクウケ6906ZZ	BALL BEARING, 6906ZZ	
489	S19959101	3	スペーサ	SPACER	
490	151626001	3	サラネジ3.57X14	SCREW, FLAT M3.57X14	
491	S15002200	1	シリンダ25X15クミ	CYLINDER ASSY, 25X15	
491-1	S15003100	1	シリンダ25X15	CYLINDER, 25X15	
491-2	S23741000	2	エルボユニオン4M5	ELBOW UNION, 4M5	
492	018503536	4	アナボルト5X35	BOLT, SOCKET M5X35	
494	S41609000	1	シリンダ16X30クミ	CYLINDER ASSY, 16X30	
494-1	S24175000	1	シリンダ16X30	CYLINDER, 16X30	
494-2	S12150000	2	ホースエルボM-5HL-4	TUBE ELBOW, M-5HL-4	
494-3	S37454000	1	1ヤマナツクルジョイント	KNUCLE JOINT	
495	S41610001	1	シテンジク2	FULCRUM SHAFT, 2	
496	048050142	1	トメワジクヨウC5	RETAINING RING, C5	
497	S41611001	1	シテンジク	FULCRUM SHAFT	
498	048050142	1	トメワジクヨウC5	RETAINING RING, C5	
502	S41612001	1	メスストツバ	KNIFE STOPPER	
503	018400836	1	アナボルト4X8	BOLT, SOCKET M4X8	
510	S27852001	1	メスドダイ	KNIFE BASE	
511	018401636	2	アナボルト4X16	BOLT, SOCKET M4X16	
512	028040246	2	バネザガネ2-4	WASHER, SPRING 2-4	
513	025040236	1	ヒラザガネチユウ4	WASHER, PLAIN M 4	
514	S41613001	1	メスレンケツボウ	KNIFE CONNECTING BAR	
515	S41619001	1	メスジョイント	KNIFE JOINT	
516	021500102	2	ナツト1シユ5	NUT, 1 M5	
517	S23709001	1	イドウハ	MOVABLE KNIFE	
518	148417001	1	ダンネジ4.37	SHOULDER SCREW, SM4.37	
519	S23710001	1	ループササエ	LOOP SUPPORT	
520	105288001	2	シメネジ2.38	SCREW, SM2.38	
521	S23711001	1	イドウハアンナイ	MOVABLE KNIFE GUIDE	
522	S41615001	1	ループササエT	LOOP SUPPORT, T	
523	S13385001	1	シメネジ3.57X10	SCREW, SM3.57X10	
524	025350236	1	ヒラザガネチユウ3.5	WASHER, PLAIN M 3.5	
525	100257010	3	シメネジ3.57	SCREW, SM3.57	
526	S27853001	1	イドウハオサエ	MOVABLE KNIFE PRESSER	
527	018300822	2	アナボルト3X8	BOLT, SOCKET M3X8	

From the library of: Diamond Needle Corp

D4. フィーダー関係 / Feeder mechanism / Knopfsortierer / Tricur de boutons / Mecanismo de botones

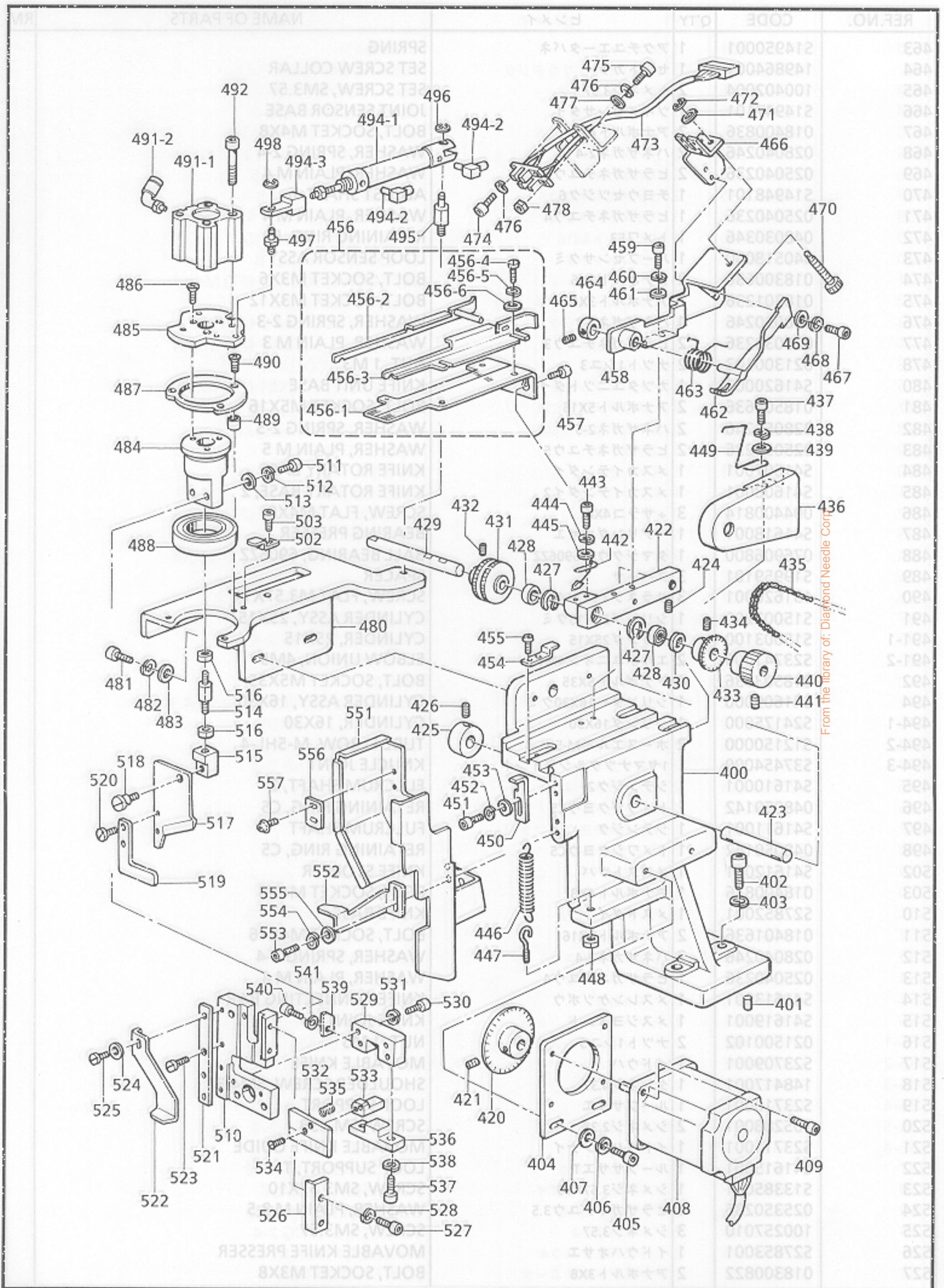

From the library of: Diamond Needle Corp.

D4. フィーダー関係 / Feeder mechanism / Knopfsortierer / Tricur de boutons  
 / Mecanismo de botones

REF.NO.	CODE	Q'TY	ヒンメイ	NAME OF PARTS	RM
528	028030242	2	バネザガネ2-3	WASHER, SPRING 2-3	
529	S23713001	1	コテイハホルダー	FIXED KNIFE HOLDER	
530	018401422	2	アナボルト4X14	BOLT, SOCKET M4X14	
531	028040242	2	バネザガネ2-4	WASHER, SPRING 2-4	
532	S23714001	1	コテイハ	FIXED KNIFE	
533	S23715001	1	コテイハジク	FIXED KNIFE SHAFT	
534	141542001	2	サラネジ3.18	SCREW, FLAT SM3.18	
535	S35020001	2	スプレダースプリング	SPREDER SPRING	
536	S23717001	1	コテイハオサエ	FIXED KNIFE SUPPORT	
537	018401222	2	アナボルト4X12	BOLT, SOCKET M4X12	
538	028040242	2	バネザガネ2-4	WASHER, SPRING 2-4	
539	S23718001	1	キリクスガイド	CLIPPING DISPOSAL GUIDE	
540	018300622	1	アナボルト3X6	BOLT, SOCKET M3X6	
541	028030242	1	バネザガネ2-3	WASHER, SPRING 2-3	
551	S41601001	1	キリクスカバーA	CLIPPING DISPOSAL COVER, A	
552	S41614001	1	ループササエB	LOOP SUPPORT, B	
553	018401236	2	アナボルト4X12	BOLT, SOCKET M4X12	
554	028040246	2	バネザガネ2-4	WASHER, SPRING 2-4	
555	025040236	2	ヒラザガネチユウ4	WASHER, PLAIN M 4	
556	S23794001	1	キリクスカバーB	CLIPPING DISPOSAL COVER, B	
557	052300606	2	ナベコバネヒラ3X6	SCREW, PAN (S/P WASHER) M3X6	
14-6	402887001	2	ワザガネ3.2	WASHER, 3.2	
14-7	062366712	2	ナベコ318-40X7	SCREW, PAN SM3.18-40X7	
14-8	153050000	2	オオカマタイフエルト	SHUTTLE RACE BASE FELT	
14-9	S02877000	2	クミヒモ4X4	WICK, 4X4 (L = 350)	
15	013760612	1	トメネジ5.95クボミ	SET SCREW, (CP) SM5.95	
16	052678001	1	カマチヨウツジク	SHUTTLE HOOK ADJUST STUD	
17	081003670	1	リングPW3	O RING, PW3	
18	048080342	1	リングE8	RETAINING RING, E8	
19	S41712001	1	ドライバー	DRIVER	
20	018501422	1	アナボルト5X14	BOLT, SOCKET M5X14	
21	120438001	1	ミソツ0ピン	DOWEL PIN	
100	152686001	1	オオカマB	SHUTTLE HOOK BASE, B	
101	S15663991	1	ナカカマB	SHUTTLE HOOK BOX ASSY, L B	
102	S18974101	1	ボビンケースLAN	BOBBIN CASE ASSY, LAN	
102-1	S16074101	1	ケースA	TENSION SPRING, A	
102-2	S16492101	1	ボビンケースバネネジ	SCREW, BOBBIN CASE SPRING	
102-3	S15667001	1	クウテンボウシバネ	BOBBIN TENSION SPRING	
103	S15665001	1	ボビンLA	BOBBIN, LA	

From the library of: Diamond Needle Corp

E. 下軸関係 / Lower shaft mechanism / Untere Welle / Mécanisme de l'arbre inférieur / Mecanismo del eje inferior

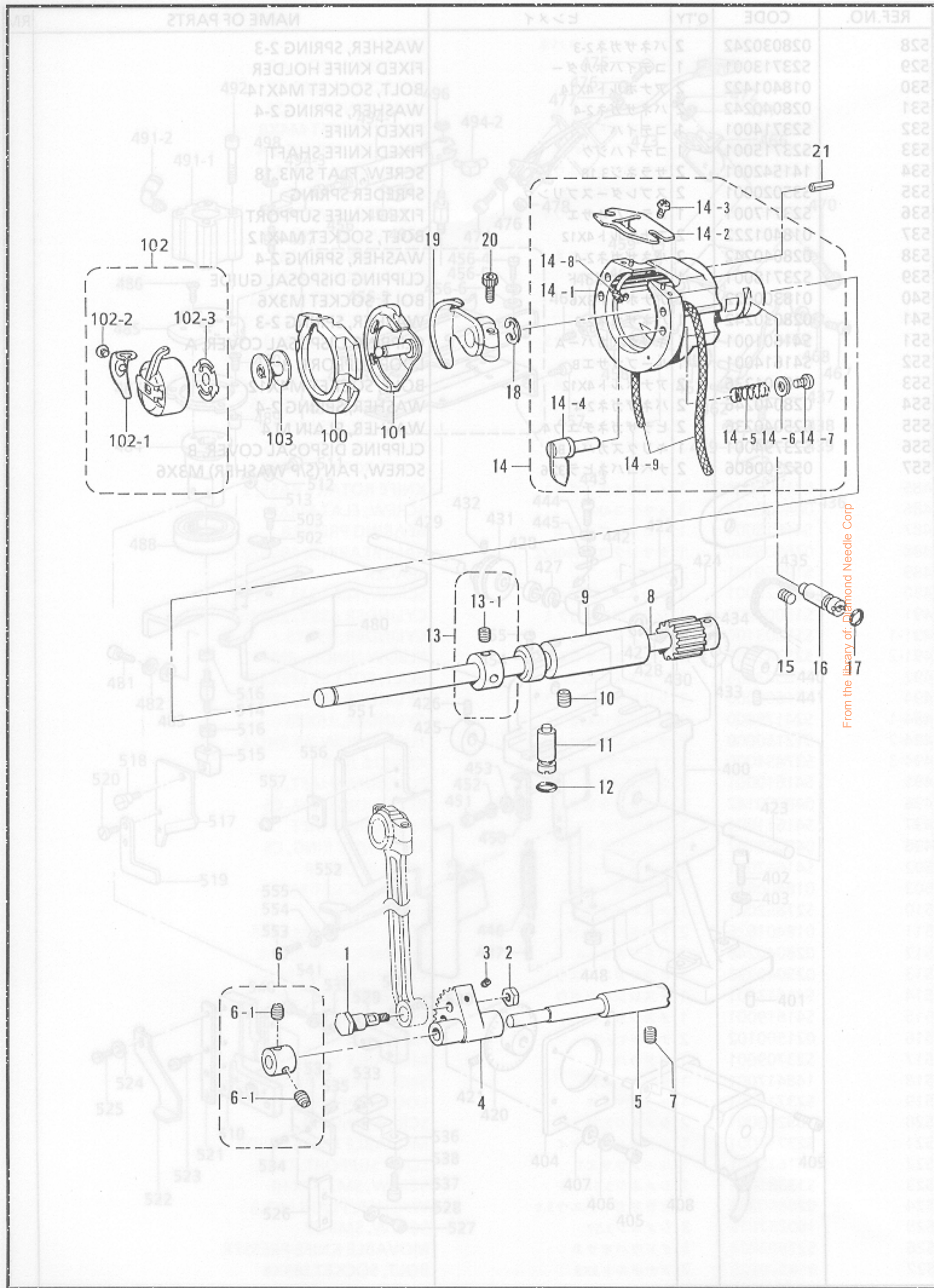

From the library of: Diamond Needle Corp

E. 下軸関係 / Lower shaft mechanism / Untere Welle / Mécanisme de l'arbre inférieur  
 / Mecanismo del eje inferior

REF.NO.	CODE	Q'TY	ヒンメイ	NAME OF PARTS	RM
1	141786001	1	クランクロッドダンネジ	CRANK ROD SHOULDER SCREW	
2	100090004	1	ナツト7.14	NUT, SM7.14	
3	014680622	1	アナトメネジ4.37クボミ	SET SCREW, SOCKET (CP) SM4.37	
4	152245001	1	ヨウドウギヤ	ROCK GEAR	
5	S37978051	1	ヨウドウギヤジク	ROCK GEAR SHAFT	
6	181995001	1	セットカラークミ	SET SCREW COLLAR ASSY	
6-1	101706001	2	トメネジ6.35	SET SCREW, SM6.35	
7	014760622	1	アナトメネジ5.95	SET SCREW, SOCKET SM5.95	
8	S41710001	1	シタジククミ	LOWER SHAFT ASSY	
9	S37981051	1	シタジクメタル	LOWER SHAFT BUSH	
10	014760622	1	アナトメネジ5.95	SET SCREW, SOCKET SM5.95	
11	152678001	1	カマチヨウセツジク	SHUTTLE HOOK ADJUST STUD	
12	081003670	1	リングPW3	O RING, PW3	
13	S03704001	1	セットカラークミ	SET SCREW COLLAR ASSY	
13-1	014770622	2	アナトメネジ6.35クボミ	SET SCREW, SOCKET (CP) SM6.35	
14	S02427201	1	オオカマタイクミ	SHUTTLE RACE BASE ASSY	
14-1	S02428001	1	オオカマタイ	SHUTTLE RACE BASE	
14-2	S02429101	1	カマイトアンナイ	SHUTTLE RACE THREAD GUIDE	
14-3	062660412	2	ナベコ318-40X4	SCREW, PAN SM3.18-40X4	
14-4	152683001	2	オオカマトリツケツメ	SHUTTLE HOOK BASE SET CLAW	
14-5	152684101	2	オオカマトリツケバネ	SHUTTLE HOOK BASE SPRING	
14-6	402887001	2	ザガネ3.2	WASHER, 3.2	
14-7	062660712	2	ナベコ318-40X7	SCREW, PAN SM3.18-40X7	
14-8	153050000	2	オオカマタイフェルト	SHUTTLE RACE BASE FELT	
14-9	S02877000	2	クミヒモ4X4	WICK, 4X4 (L = 350)	
15	013760612	1	トメネジ5.95クボミ	SET SCREW, (CP) SM5.95	
16	152678001	1	カマチヨウセツジク	SHUTTLE HOOK ADJUST STUD	
17	081003670	1	リングPW3	O RING, PW3	
18	048080342	1	トメワE8	RETAINING RING, E8	
19	S41712001	1	ドライバー	DRIVER	
20	018501422	1	アナボルト5X14	BOLT, SOCKET M5X14	
21	120438001	1	ミゾツキピン	DOWEL PIN	
100	152686001	1	オオカマB	SHUTTLE HOOK BASE, B	
101	S15663991	1	ナカカマLBハコクミ	SHUTTLE HOOK BOX ASSY, L B	
102	S18974101	1	ボビンケースクミLAN	BOBBIN CASE ASSY, LAN	
102-1	S16074101	1	ケースチヨウシバネA	TENSION SPRING, A	
102-2	S16492101	1	ボビンケースバネネジ	SCREW, BOBBIN CASE SPRING	
102-3	S15667001	1	クウテンボウシバネ	BOBBIN TENSION SPRING	
103	S15665001	1	ボビンLA	BOBBIN, LA	
12-1	S41829001	1	イトキリレバースジク	THREAD TRIMMER LEVER SHAFT	
12-2	S02429101	1	カマイトアンナイ	SHUTTLE RACE THREAD GUIDE	
12-3	062660412	2	ナベコ318-40X4	SCREW, PAN SM3.18-40X4	
12-4	152683001	2	オオカマトリツケツメ	SHUTTLE HOOK BASE SET CLAW	
12-5	152684101	2	オオカマトリツケバネ	SHUTTLE HOOK BASE SPRING	
12-6	402887001	2	ザガネ3.2	WASHER, 3.2	
12-7	062660712	2	ナベコ318-40X7	SCREW, PAN SM3.18-40X7	
12-8	153050000	2	オオカマタイフェルト	SHUTTLE RACE BASE FELT	
12-9	028350243	1	ザガネ2-3.5	WASHER, SPRING 2-3.5	
12-10	025030335	1	ザガネ2.3	WASHER, PLAIN L3	
12-11	S02877000	2	クミヒモ4X4	WICK, 4X4 (L = 350)	
13	012500536	1	アナヒモ5X5	SET SCREW, SOCKET (FI) M5X5	
14	152678001	1	カマチヨウセツジク	SHUTTLE HOOK ADJUST STUD	
15	081003670	1	リングPW3	O RING, PW3	
16	048080342	1	トメワE8	RETAINING RING, E8	
17	S41829001	1	イトキリレバースジク	THREAD TRIMMER LEVER SHAFT	
18	018501422	1	アナボルト5X14	BOLT, SOCKET M5X14	
52	S41829001	1	イトキリレバースジク	THREAD TRIMMER LEVER SHAFT	
53	153596001	1	ザガネ	WASHER	
54	148239001	1	アンゴジクカラー	THRUST COLLAR	

From the library of: Diamond Needle Corp

F. 下軸モジュール関係 / Lower shaft module mechanism / Module für untere Welle  
 / Mécanisme de module d'arbre inférieur / Mecanimo de módulo de eje inferior

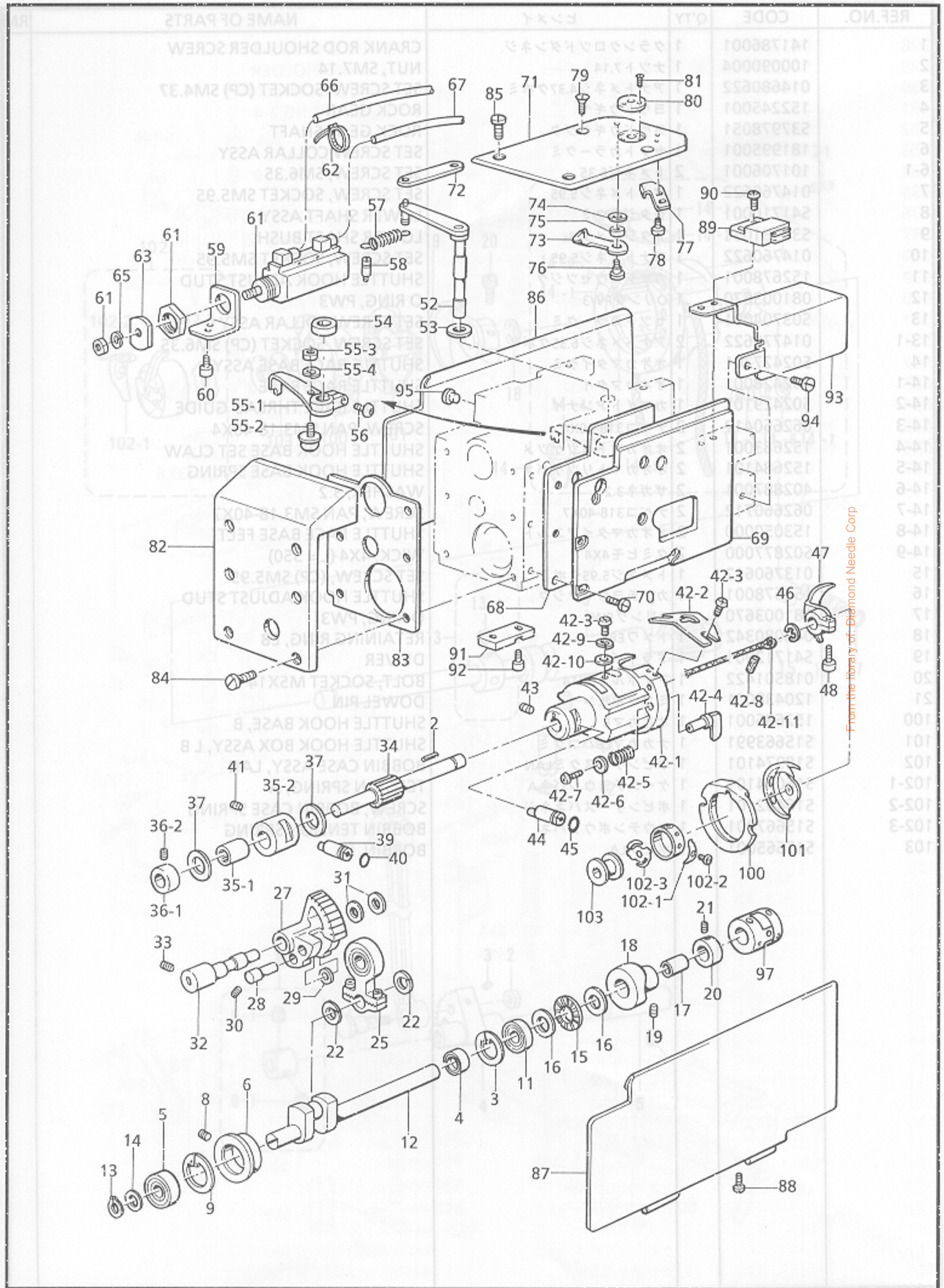

From the library of: Diamond Needle Corp

F. 下軸モジュール関係 / Lower shaft module mechanism / Module für untere Welle  
 / Mécanisme de module d'arbre inférieur / Mecanimo de módulo de eje inferior

REF.NO.	CODE	Q'TY	ヒンメイ	NAME OF PARTS	RM
25	120438001	1	ミゾツキピン	DOWEL PIN	
35-1	048260242	1	トメワアナヨウC26	RETAINING RING, C26	
45-2	S41808000	1	オイルシール	OIL SEAL	
55-3	072600080	1	タマジクウケ 6000ZZ	BALL BEARING, 6000ZZ	
65-4	S41809000	1	タマジクウケケース	BALL BEARING CASE	
86	012500536	1	アナヒラ5X5	SET SCREW, SOCKET (FT) M5X5	
97	048260242	1	トメワアナヨウC26	RETAINING RING, C26	
11	072600080	1	タマジクウケ 6000ZZ	BALL BEARING, 6000ZZ	
12	S41810001	1	BMクランクジク	BM-CRANK SHAFT	
13	048100142	1	トメワジクヨウC10	RETAINING RING, C10	
14	S09027001	1	ヒラザガネシヨウ10	WASHER, PLAIN S 10	
15	072512260	1	スラストベアリング	THRUST BEARING	
16	S41811000	2	スラストザガネ	WASHER, THURST	
17	S41812001	1	カムスリーブ	CAM SLEEVE	
18	S41813001	1	イトキリカム	THREAD TRIMMING CAM	
19	013719412	2	トメネジ4.76クボミ	SET SCREW, (CP) SM4.76	
20	150594001	1	セットカラー	SET SCREW COLLAR	
21	014760622	2	アナトメネジ5.95	SET SCREW, SOCKET SM5.95	
22	S41814000	2	ロッドフレドメ1.6	ROD STOPPER, 1.6	
25	S41815001	1	BMクランクロッドクミ	BM-CRANK ROD ASSY	
27	S41819001	1	ヨウドウギヤ	ROCK GEAR	
28	S41820001	1	チヨウシンジク	BUSHING	
29	122257001	1	ザガネ	WASHER	
30	151602002	2	トメネジ4.37	SET SCREW, SM4.37	
31	153596001	2	ザガネ	WASHER	
32	S41821001	1	ヨウドウギヤジク	ROCK GEAR SHAFT	
33	012500536	1	アナヒラ5X5	SET SCREW, SOCKET (FT) M5X5	
34	S41822001	1	カマジク	SHUTTLE HOOK SHAFT	
35	S41823001	1	カマジクメタルクミ	SHUTTLE HOOK SHAFT BUSHING ASSY	
35-1	S13744001	1	ニードルジクウケ9.53	NEEDLE BEARING, 9.53	
35-2	S41824001	1	カマジクメタル	SHUTTLE HOOK SHAFT BUSHING	
36	S03490001	1	セットカラークミ	SET SCREW COLLAR ASSY	
36-1	115127001	1	セットカラー	SET SCREW COLLAR	
36-2	013710512	2	トメネジ4.76クボミ	SET SCREW, (CP) SM4.76	
37	S02556001	2	ザガネ	WASHER	
39	152678001	1	カマチヨウセツジク	SHUTTLE HOOK ADJUST STUD	
40	081003670	1	OリングPW3	O RING, PW3	
41	012500536	1	アナヒラ5X5	SET SCREW, SOCKET (FT) M5X5	
42	S41825001	1	オオカマタイBMクミ	SHUTTLE HOOK BASE ASSY, BM	
42-1	S41826001	1	オオカマタイBM	SHUTTLE HOOK BASE	
42-2	S02429101	1	カマイトアンナイ	SHUTTLE RACE THREAD GUIDE	
42-3	062660412	3	ナベコ318-40X4	SCREW, PAN SM3.18-40X4	
42-4	152683001	2	オオカマトリツケツメ	SHUTTLE HOOK BASE SET CLAW	
42-5	152684101	2	オオカマトリツケバネ	SHUTTLE HOOK BASE SPRING	
42-6	402887001	2	ザガネ3.2	WASHER, 3.2	
42-7	062660712	2	ナベコ318-40X7	SCREW, PAN SM3.18-40X7	
42-8	153050000	2	オオカマタイフェルト	SHUTTLE RACE BASE FELT	
42-9	028350243	1	バネザガネ2-3.5	WASHER, SPRING 2-3.5	
42-10	025030335	1	ヒラザガネダイ3	WASHER, PLAIN L 3	
42-11	S02877000	2	クミヒモ4X4	WICK, 4X4 (L = 350)	
43-1	012500536	1	アナヒラ5X5	SET SCREW, SOCKET (FT) M5X5	
44-2	152678001	1	カマチヨウセツジク	SHUTTLE HOOK ADJUST STUD	
45-2-3	081003670	1	OリングPW3	O RING, PW3	
46-3	048080342	1	トメワE8	RETAINING RING, E8	
47	S41712001	1	ドライバー	DRIVER	
48	018501422	1	アナボルト5X14	BOLT, SOCKET M5X14	
52	S41829001	1	イトキリレバージク	THREAD TRIMMER LEVER SHAFT	
53	153596001	1	ザガネ	WASHER	
54	148239001	1	ゼンゴジクカラー	THRUST COLLAR	

From the library of Diamond Needle Corp



F. 下軸モジュール関係 / Lower shaft module mechanism / Module für untere Welle  
 / Mécanisme de module d'arbre inférieur / Mecanimo de módulo de eje inferior

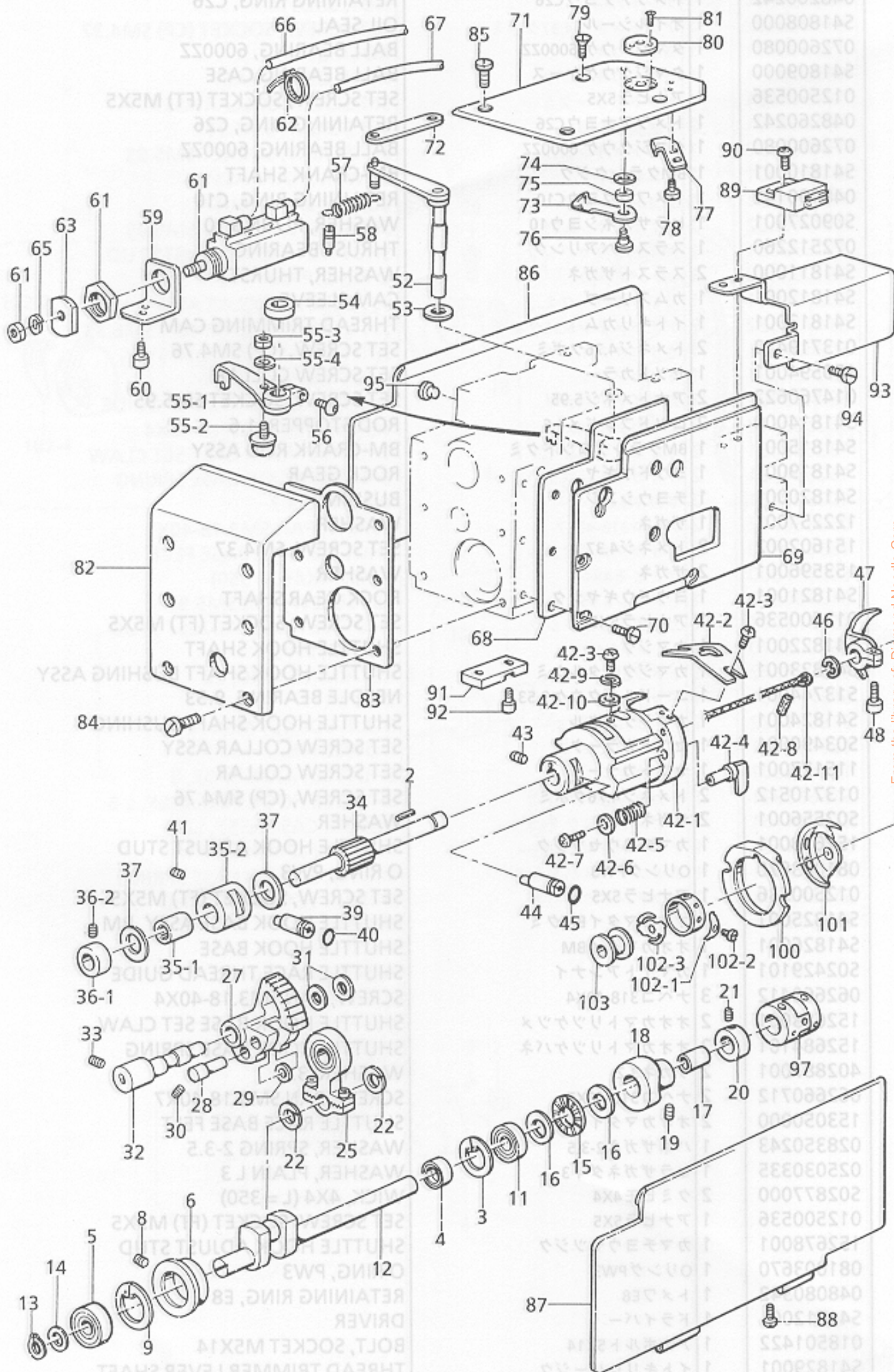

From the library of Diamond Needle Corp

F. 下軸モジュール関係 / Lower shaft module mechanism / Module für untere Weile  
 / Mécanisme de module d'arbre inférieur / Mecanimo de módulo de eje inferior

REF.NO.	CODE	Q'TY	ヒンメイ	NAME OF PARTS	RM
55	S41830001	1	イトキリレバークミ	THREAD TRIMMER LEVER ASSY	
55-1	S41831001	1	イトキリレバー	THREAD TRIMMER LEVER	
55-2	154590001	1	コロジクCクミ	ROLLER SHAFT ASSY, C	
55-3	105234003	1	ナット4.37	NUT, SM4.37	
55-4	028680242	1	バネザガネ2-4.37	WASHER, SPRING 2-4.37	
56	S41850001	1	ボタンヘッドネジ5X14	SCREW, M5X14	
57	S41832001	1	イトキリバネ	SPRING, THREAD TRIMMER	
58	107657001	1	バネカケ	SPRING HOOK	
59	S41833001	1	イトキリシリンドトリツケイタ	SET PLATE, THREAD TRIMMER CYLINDER	
60	018400636	2	アナボルト4X6	BOLT, SOCKET M4X6	
61	S41834000	1	イトキリシリンドクミ	THREAD TRIMMER CYLINDER	
62	228475000	1	ケツソクバンド1.9X80	FASTENING BAND, 1.9X80	
63	S41836001	1	イトキリレバーサドウイタ	THREAD TRIMMER LEVER DRIVING PLATE	
65	028050246	1	バネザガネ2-5	WASHER, SPRING 2-5	
66	S41943000	1	エアホース0425S145B	AIR TUBE, 0425S (L = 1450)	
67	S31706000	1	エアーチューブ4X1510	AIR TUBE, (L = 1510)	
68	S41837000	1	BMバツキン	BM-PACKING	
69	S41838001	1	BMサイドカバー	BM-SIDE COVER	
70	106629002	6	シメネジ4.37	SCREW, SM4.37	
71	S41839001	1	BMハリイタ	BM-NEEDLE PLATE	
72	S41840001	1	イトキリレンカン	THREAD TRIMMER CONNECTING ROD	
73	S10205001	1	イドウハクミ	MOVABLE KNIFE ASSY	
74	S10208001	1	イドウハカンザ <t=0.4>	WASHER, MOVABLE KNIFE <t=0.4>	
74	S10208002	1	イドウハカンザ <t=0.5>	WASHER, MOVABLE KNIFE <t=0.5>	
74	S10208003	1	イドウハカンザ <t=0.6>	WASHER, MOVABLE KNIFE <t=0.6>	
75	S00705001	1	イドウハカラー	MOVABLE KNIFE COLLAR	
76	S10209101	1	シメネジ4.37	SCREW, SM4.37	
77	S41738001	1	コテイハ	FIXED KNIFE	
78	111140002	2	シメネジ2.38	SCREW, SM2.38	
79	100032004	2	サラネジ4.37	SCREW, FLAT SM4.37	
80	S10212101	1	ハリアナイタE	NEEDLE HOLE PLATE, E	
81	100360003	2	サラネジ2.38	SCREW, FLAT SM2.38	
82	S41841009	1	BMフロントカバー	BM-FRONT COVER	
83	S41842000	1	フロントバツキン	FRONT PACKING	
84	106629002	6	シメネジ	SCREW, SM4.37	
85	153208002	2	シメネジ	SCREW, SM4.37	
86	S41843009	1	BMカバーR	BM-COVER, R	
87	S41844009	1	BMカバーL	BM-COVER, L	
88	060300416	8	バインド3X4	SCREW, BIND M3X4	
89	S41845000	2	マグネットキャッチ	MAGNET CATCH	
90	060300612	4	バインド M3X6	SCREW, BIND M3X6	
91	S41846001	1	キー18	KEY, 18	
92	018400636	2	アナボルト4X6	BOLT, SOCKET M4X6	
93	S41847009	1	BMモータカバー	BM-MOTOR COVER	
94	106629002	1	シメネジ4.37	SCREW, SM4.37	
95	S41848000	4	ゴムセン6.6	RUBBER CAP, 6.6	
97	S41849000	1	カツブリング8	COUPLING, 8	
100	152686001	1	オオカマB	SHUTTLE HOOK BASE, B	
101	S15662991	1	ナカカマLAハコクミ	LARGE SHUTTLE HOOK BOX ASSY, LA	
102	S18974101	1	ボビンケースクミLAN	BOBBIN CASE ASSY, LAN	
102-1	S16074101	1	ケースチヨウシバネA	TENSION SPRING, A	
102-2	S16492101	1	ボビンケースバネネジ	SCREW, BOBBIN CASE SPRING	
102-3	S15667001	1	クウテンボウシバネ	BOBBIN TENSION SPRING	
103	S15665001	1	ボビンLA	BOBBIN, LA	

From the library of: Diamond Needle Corp



REF.NO.	CODE	Q'TY	ヒンメイ	NAME OF PARTS	RM
1	152948001	1	オイルポットマド	OIL WINDOW	
2	S07333001	1	オイルクチパイプS	OIL FEEDING PIPE, S	
3	S07456000	1	ビニールチューブ	OIL TUBE (L = 160)	
4	148738000	1	クミヒモ	WICK, (L = 335)	
5	107149001	1	フェルト	FELT	
6	S37983001	1	ウワジクキユウユササエ	WICK SUPPORT	
7	062680612	1	ナベコ4.37-40X6	SCREW, PAN SM4.37-40X6	
8	025680232	1	ヒラザガネチユウ4.37	WASHER, PLAIN M 4.37	
9	028680242	1	バネザガネ2-4.37	WASHER, SPRING 2-4.37	
10	S10478000	1	ロツドキユウユフェルト	FELT	
11	S34986000	1	ビニールチューブ	OIL TUBE, (L = 135)	
12	153920001	1	クミヒモ4X4	WICK, 4X4 (L = 300)	
13	107149001	1	フェルト	FELT	
14	S21527001	1	テンピンキユウユササエ	WICK SUPPORT	
15	S10162201	1	ハリボウヒモササエ	WICK SUPPORT	
16	060670512	1	バインド357-40X5	SCREW, BIND SM3.57-40X5	
17	S37984000	1	ビニールチューブ	OIL TUBE, (L = 290)	
18	S41715001	1	クミヒモ4X4	WICK, 4X4 (L = 800)	
19	153562001	1	ヒラクミヒモ	FLAT WICK, (L = 150)	
20	151927001	1	クラッチフェルト	CLUTCH FELT	
21	104567001	1	クミヒモササエ	WICK SUPPORT	
23	S37985000	1	スイアゲフェルト	FELT	
24	S37986000	1	ビニールチューブ	OIL TUBE, (L = 440)	
25	S18093100	1	クミヒモ4X4	WICK, 4X4 (L = 1100)	
26	145547001	1	チューブホルダ	TUBE HOLDER	
27	062670512	1	ナベコ357-40X5	SCREW, PAN SM3.57-40X5	
28	S37987001	1	シタジクキユウユササエ	FELT SUPPORT	
29	S37988000	1	シタジクキユウユフェルト	FELT	
30	062680612	1	ナベコ4.37-40X6	SCREW, PAN SM4.37-40X6	
31	S09043000	1	フェルト	FELT	
32	152948001	1	オイルポットマド	OIL WINDOW	
34	S34983000	1	ビニールチューブ	OIL TUBE (L = 160)	
35	S34986000	1	ビニールチューブ	OIL TUBE (L = 135)	
36	S34982000	1	ビニールチューブ	OIL TUBE, (L = 70)	
37	153920001	1	クミヒモ4X4	WICK, 4X4 (L = 300)	
38	152969001	1	コードササエカネ	CORD SUPPORT	
39	062670512	1	ナベコ357-40X5	SCREW, PAN SM3.57-40X5	
40	148738000	1	クミヒモ	WICK, (L = 335)	
41	148738000	1	クミヒモ	WICK, (L = 335)	
42	152956001	1	クミヒモ4X4	WICK, 4X4 (L = 500)	
44	228475000	3	ケツソクバンド1.9X80	FASTENING BAND, 1.9X80	
45	S37984000	1	ビニールチューブ	OIL TUBE, (L = 290)	
46	S41715001	1	クミヒモ4X4	WICK, 4X4 (L = 800)	
50	S41716000	1	クミヒモ	WICK, (L = 80)	
13	028040246	2	ヒラザガネチユウ4	WASHER, PLAIN M 4	
14	025040236	2	ヒラザガネチユウ4	WASHER, PLAIN M 4	
15	S41936000	2	エアホース04255035	AIR TUBE, 04255 (L = 350)	
17	S41935000	2	エアホース04255035	AIR TUBE, 04255 (L = 350)	
18	S28741000	1	エアチューブ	AIR TUBE	
19	S19557000	2	コガタユニオンワイヤ	MINIATURE UNION, Y	
20	S41943000	2	エアホース04255145B	AIR TUBE, 04255 (L = 145)	
21	S41872001	1	イトハライスライドイタ	THREAD WIPER SLIDE PLATE, F	
22	018400836	2	アナボルト4X8	BOLT, SOCKET M4X8	
23	028040246	2	バネザガネ2-4	WASHER, SPRING 2-4	
24	025040236	2	ヒラザガネチユウ4	WASHER, PLAIN M 4	
25	S41873001	1	イトハライスライドイタR	THREAD WIPER SLIDE PLATE, R	
26	018400836	2	アナボルト4X8	BOLT, SOCKET M4X8	
27	028040246	2	バネザガネ2-4	WASHER, SPRING 2-4	
28	025040236	1	ヒラザガネチユウ4	WASHER, PLAIN M 4	

From the library of: Diamond Needle Corp

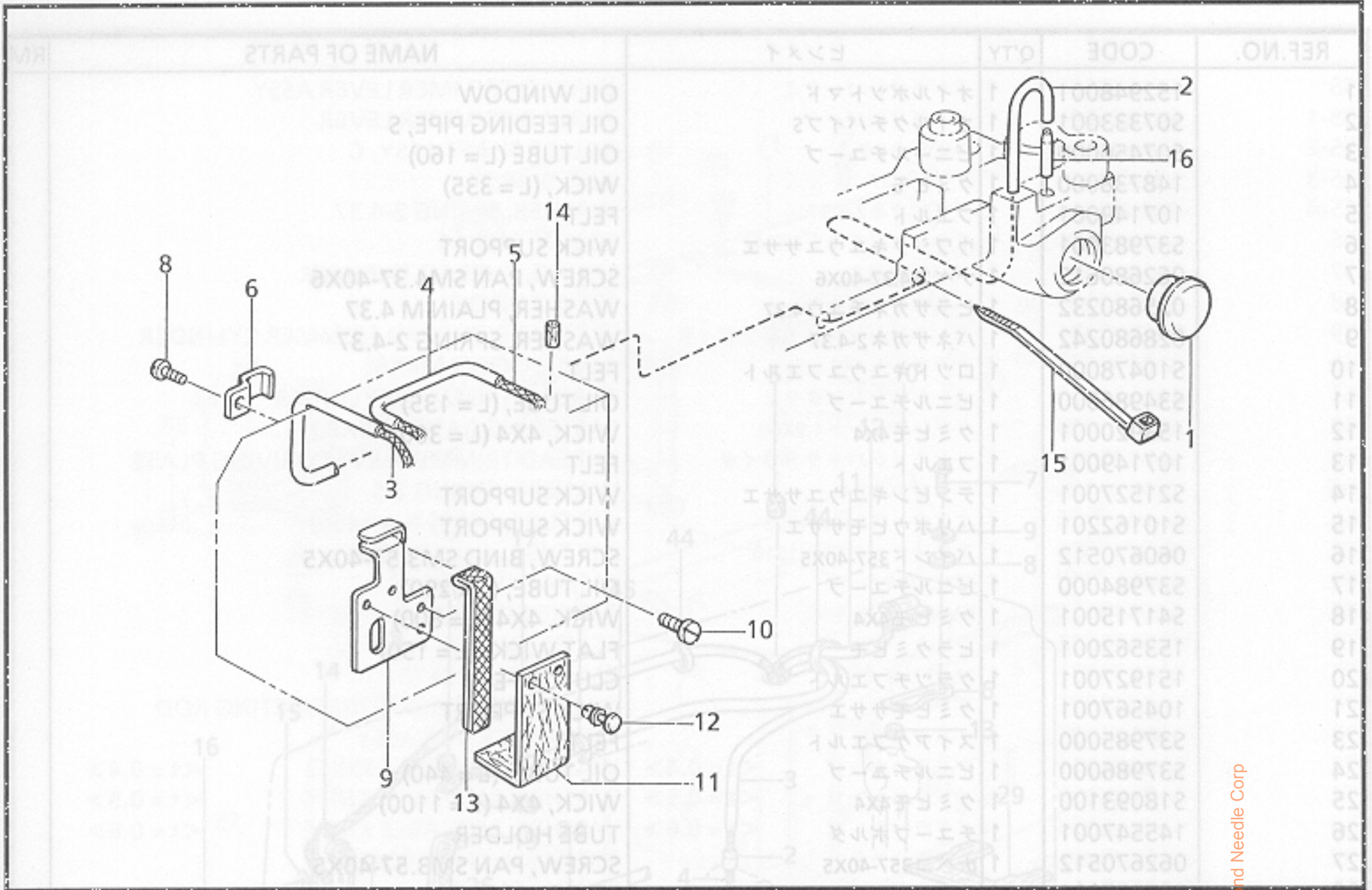

151-705-350

H . 糸払い関係 / Thread wiper mechanism / Fadenwischvorrichtung / Mécanisme de tire-fil / Mecanismo del limpiador de hilo

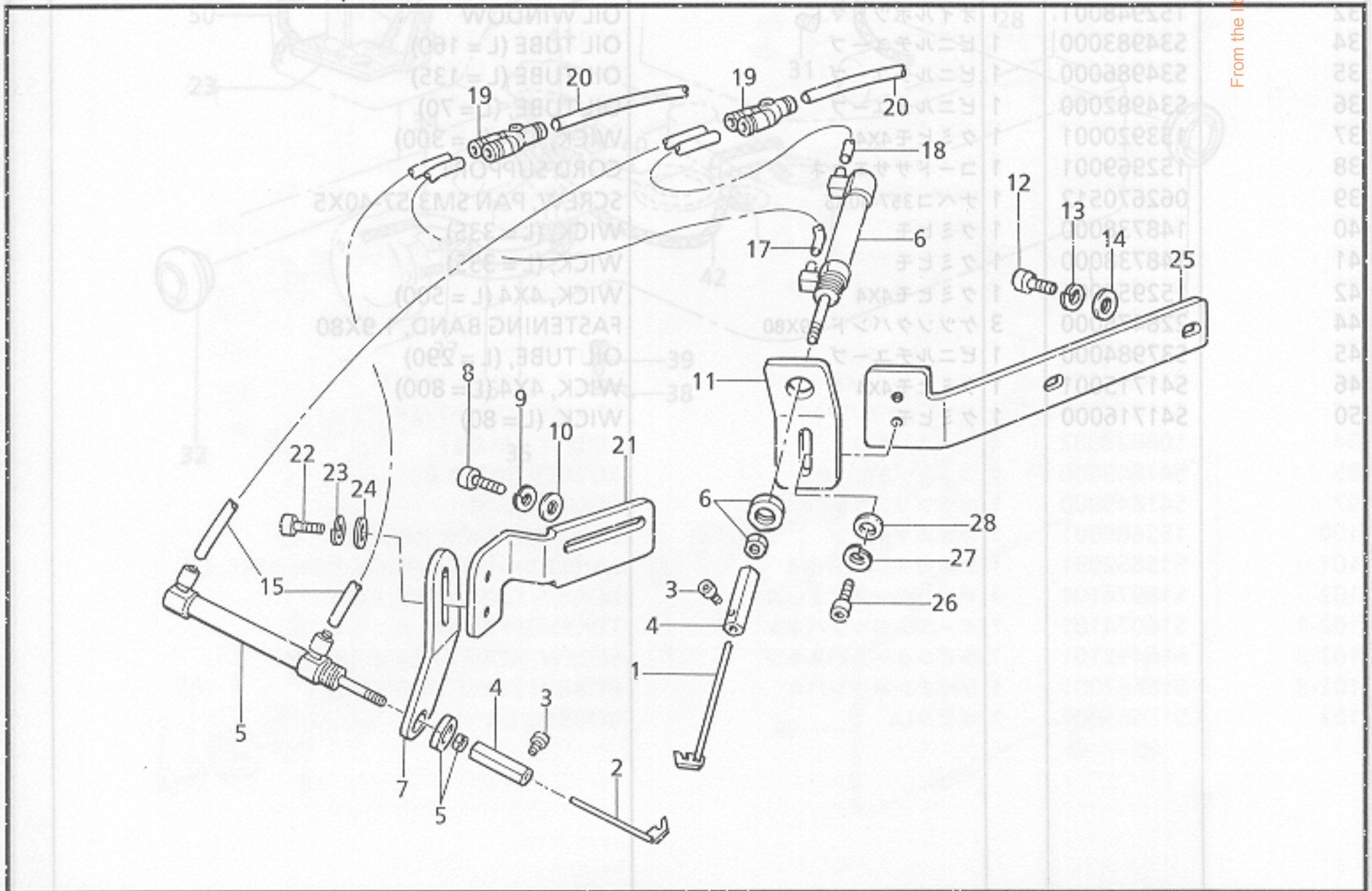

From the library of Diamond Needle Corp

REF.NO.	CODE	Q'TY	ヒンメイ	NAME OF PARTS	RM
1	152948001	1	オイルポットマド	OIL WINDOW	
2	S41852000	1	ビニールチューブ	OIL TUBE, (L = 480)	
3	S41853001	1	クミヒモ4X4	WICK, 4X4 (L = 700)	
4	S34982000	1	ビニールチューブ	OIL TUBE, (L = 70)	
5	S41855001	1	クミヒモ4X4	WICK, 4X4 (L = 40)	
6	140647001	1	コードオサエ	CORD HOLDER	
8	062670512	1	ナベコ357-40X5	SCREW, PAN SM3.57-40X5	
9	S41856000	1	BMタイキユウユササエ	BM-BASE WICK SUPPORT	
10	106629002	6	シメネジ4.37	SCREW, SM4.37	
11	S41857001	1	BMトウシンササエフェルト	FELT, BM WICK SUPPORT	
12	S35001000	2	ナイロンリベット	NYLON RIVET	
13	153562001	1	ヒラクミヒモ	FLAT WICK, (L = 150)	
14	106436001	1	フェルト	FELT	
15	228475000	1	ケツソクバンド1.9X80	FASTENING BAND, 1.9X80	
16	S07333001	1	キユウユクチパイプS	OIL FEEDING PIPE, S	
-14	149566109	4	イトチヨウシナット	TENSION NUT	
-15	148851001	2	ハリイ	THREAD TENSION ADJUST SPRING	
-16	S41726001	1	ストッパ	TENSION SPRING STOPPER	
-17	S41727001	1	ストッパ	TENSION SPRING STOPPER, L	
-18	062670512	1	ナベコ357-40X5	SCREW, PAN SM3.57-40X5	
-19	062670512	1	ナベコ357-40X5	SCREW, PAN SM3.57-40X5	
-20	08605101	1	スペーサ	SPACER	
-21	08605001	8	カラー	COLLAR	
-22	S41723001	1	ストッパ	STOPPER SUPPORT	
-23	08610101	1	調整つまみ	ADJUST THUMB	
-24	013660612	1	セットネジ	SET SCREW, T8 SM3.8	
-25	144105000	1	調整ネジ	ADJUST SCREW, T8 SM3.8	

From the library of Diamond Needle Corp

151-705-350

 H. 糸払い関係 / Thread wiper mechanism / Fadenwischvorrichtung / Mécanisme de tire-fil  
 / Mecanismo del limpiador de hilo

REF.NO.	CODE	Q'TY	ヒンメイ	NAME OF PARTS	RM
1	S07553001	1	イトハラ	THREAD WIPER	
2	S41865001	1	イトハラF	THREAD WIPER, F	
3	S07424001	2	トメネジ3.18	BOLT, SOCKET SM3.18X4	
4	S41866001	2	イトハラウデ	THREAD WIPER ARM	
5	S41867000	1	シリンダクミ	CYLINDER ASSY	
6	S41581000	1	シリンダ10X30クミ	CYLINDER ASSY, 10X30	
7	S41870001	1	イトハラササエイタF	THREAD WIPER SUPPORT PLATE, F	
8	018401036	1	アナボルト4X10	BOLT, SOCKET M4X10	
9	028040246	1	バネザガネ2-4	WASHER, SPRING 2-4	
10	025040236	1	ヒラザガネチユウ4	WASHER, PLAIN M 4	
11	S41871001	1	イトハラササエイタR	THREAD WIPER SUPPORT PLATE, R	
12	018400836	2	アナボルト4X8	BOLT, SOCKET M4X8	
13	028040246	2	バネザガネ2-4	WASHER, SPRING 2-4	
14	025040236	2	ヒラザガネチユウ4	WASHER, PLAIN M 4	
15	S41936000	2	エアホース0425S044B	AIR TUBE, 0425S (L = 440)	
17	S41935000	1	エアホース0425S035B	AIR TUBE, 0425S (L = 350)	
18	S28741000	1	エアーチューブ	AIR TUBE, (L = 300)	
19	S19557000	2	コガタユニオンワイ4	MINIATURE UNION, Y4	
20	S41943000	2	エアホース0425S145B	AIR TUBE, 0425S (L = 1450)	
21	S41872001	1	イトハラスライドイタF	THREAD WIPER SLIDE PLATE, F	
22	018400836	2	アナボルト4X8	BOLT, SOCKET M4X8	
23	028040246	2	バネザガネ2-4	WASHER, SPRING 2-4	
24	025040236	2	ヒラザガネチユウ4	WASHER, PLAIN M 4	
25	S41873001	1	イトハラスライドイタR	THREAD WIPER SLIDE PLATE, R	
26	018400836	2	アナボルト4X8	BOLT, SOCKET M4X8	
27	028040246	2	バネザガネ2-4	WASHER, SPRING 2-4	
28	025040236	2	ヒラザガネチユウ4	WASHER, PLAIN M 4	

J. 糸通シ関係 / Threading mechanism / Fadenführungsrichtung / Mécanisme de l'enfilage / Mecanismo del enhebrado

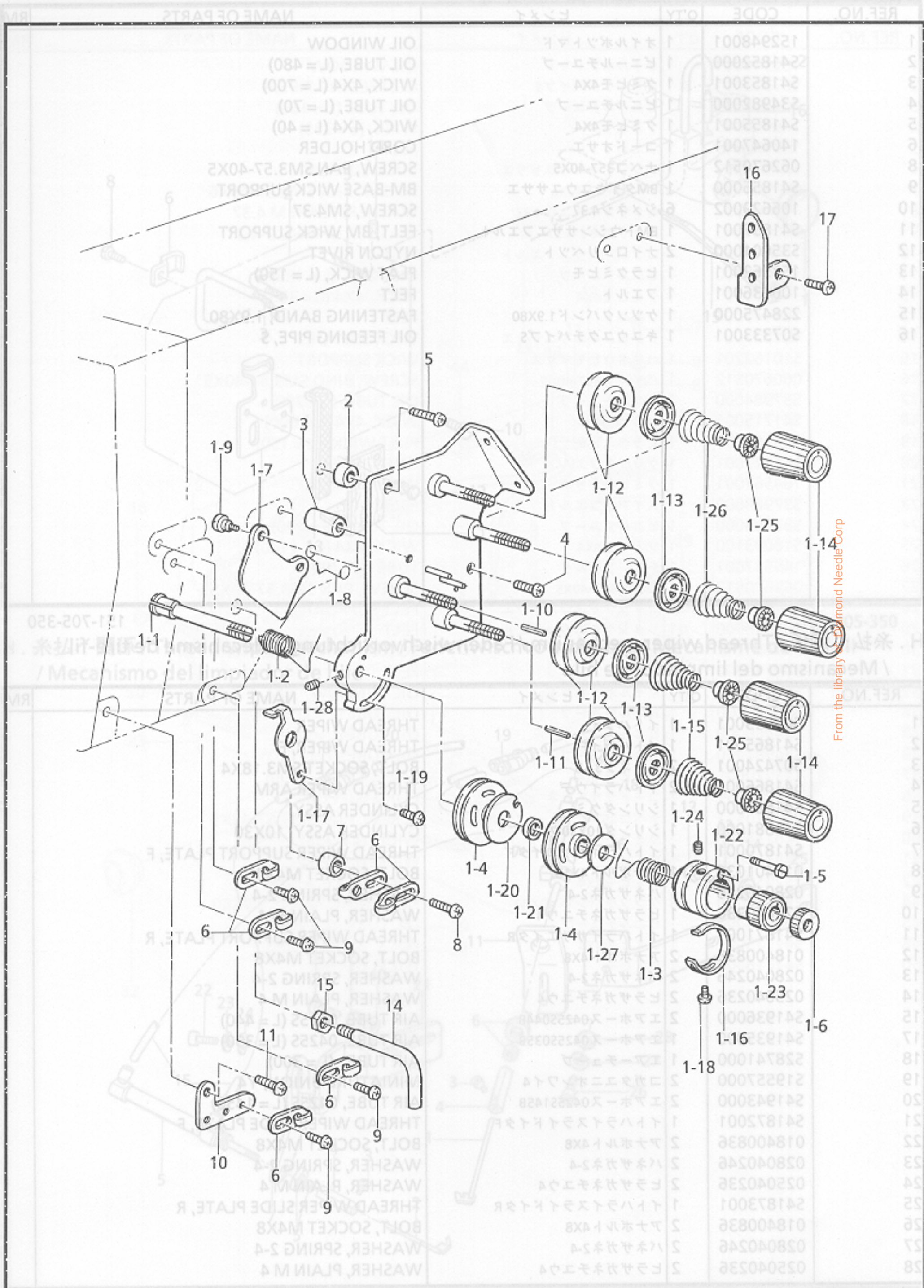

From the library of Diamond Needle Corp

J. 糸通シ関係 / Threading mechanism / Fadenführungsrichtung / Mécanisme de l'enfilage  
 / Mecanismo del enhebrado

REF.NO.	CODE	Q'TY	ヒンメイ	NAME OF PARTS	RM
1	S41719001	1	ウワイトチヨウシクミ	UPPER THREAD TENSION ASSY	
1-1	S41721001	1	チヨウシジク	THREAD TENSION STUD	
1-2	S41722001	1	イトトリバネL	TENSION SPRING, L	
1-3	S41723001	1	イトトリバネR	TENSION SPRING, R	
1-4	S41724001	2	イトトリバネアンナイクミ	TENSION SPRING GUIDE ASSY	
1-5	146124001	1	シメネジ2.38	SCREW, SM2.38	
1-6	108265009	1	イトチヨウシナツト	TENSION NUT	
1-7	S41725001	1	イトユルメイタ	TENSION RELEASE PLATE	
1-8	S38274001	1	イトユルメバネ	SPRING, TENSION RELEASE	
1-9	112712001	2	ダンネジ3.57	SHOULDER SCREW, SM3.57	
1-10	S07488001	1	イトユルメピンL	PIN, TENSION RELEASE (L)	
1-11	158769001	1	イトユルメピンR	PIN, TENSION RELEASE (R)	
1-12	145446001	8	イトチヨウシサラ	TENSION DISC	
1-13	159805001	4	イトチヨウシサラオサエ	TENSION DISC PRESSER	
1-14	149566109	4	イトチヨウシナツト	TENSION NUT	
1-15	148851001	2	ハリイトチヨウシバネ	THREAD TENSION ADJUST SPRING	
1-16	S41726001	1	イトトリバネストツバ	TENSION SPRING STOPPER	
1-17	S41727001	1	イトトリバネストツバL	TENSION SPRING STOPPER, L	
1-18	062670512	1	ナベコ357-40X5	SCREW, PAN SM3.57-40X5	
1-19	060350812	1	バインド35X8	SCREW, BIND M3.5X8	
1-20	S08605101	1	スペーサー	SPACER	
1-21	S08606001	1	カラー	COLLAR	
1-22	S41728001	1	ストツパウケ	STOPPER SUPPORT	
1-23	S08610101	1	チヨウセツツマミ	ADJUST THUMB	
1-24	013660612	1	トメネジ3.18クボミ	SET SCREW, (CP) SM3.18	
1-25	144105000	4	チヨウシバネウエザガネ	FLANGE WASHER, TENSION SPRING	
1-26	144110001	2	シタルーバイトチヨウシバネ	THREAD TENSION ADJUST SPRING	
1-27	109893002	1	ザガネ	WASHER	
1-28	012400436	1	アナヒラ4X4	SET SCREW, SOCKET (FT) M4X4	
2-15	S03303001	1	カラー	COLLAR	
3-16	S07071001	1	オサエアゲコロ	PRESSER BAR LIFTER ROLLER	
4-17	062682012	1	ナベコ437-40X20	SCREW, PAN SM4.37-40X20	
5-18	062681212	1	ナベコ437-40X12	SCREW, PAN SM4.37-40X12	
6-19	S41729001	6	アームイトアンナイ	ARM THREAD GUIDE	
7-20	153215001	1	フオトダイカラー-21	COLLAR, 21	
8-21	062671412	1	ナベコ357-40X14	SCREW, PAN SM3.57-40X14	
9-21-1	060670612	4	バインド357-40X6	SCREW, BIND SM3.57-40X6	
10-1-2	S41730001	1	アームイトアンナイガイド	GUIDE, ARM THREAD GUIDE	
11-1-3	060670612	1	バインド357-40X6	SCREW, BIND SM3.57-40X6	
14-1-4	S41731001	1	アームイトカケ	ARM THREAD GUIDE	
15-1-5	021680202	1	ナツト2シユ4.37	NUT, 2 SM4.37	
16-2	152889001	1	ミツメイトカケ	THREAD RETAINER	
17-3	062670612	2	ナベコ357-40X6	SCREW, PAN SM3.57-40X6	
2-24	025030236	1	ヒラシバネチユウ	WASHER, PLAIN SI	
2-25	158597001	1	イトマキストッパー	BOBBIN WINDER STOPPER	
2-26	S21103000	1	イトマキハーネスC	BOBBIN WINDER HARNESS C	
2-27	S18669000	1	プロテクタ0.5A	PROTECTOR 0.5A	
2-28	S31960009	1	イトマキカバー	BOBBIN WINDER COVER	
2-29	028260242	2	バネザガネ2-2.6	WASHER SPRING	
2-30	052300606	2	ナベコバネヒラ3x6	SCREW, PAN (S/P WASHER) M3X6	
2-31	S00505001	2	ロツカクスクロナツトM4	NUT, CAP M4	
3-	104450109	1-2	ゴムセン8	RUBBER CAP, 8	
4-	S41864009	1	イトマキソウチドリツケイタ	SETTING PLATE, BOBBIN WINDER ASSY	
5-	106629002	2	シメネジ4.37	SCREW, SM4.37	

From the library of: Diamond Needle Corp



K. 糸巻関係 / Bobbin winder mechanism / Spuler / Mécanisme du bobineur  
 / Mecanismo del devanador de la canilla

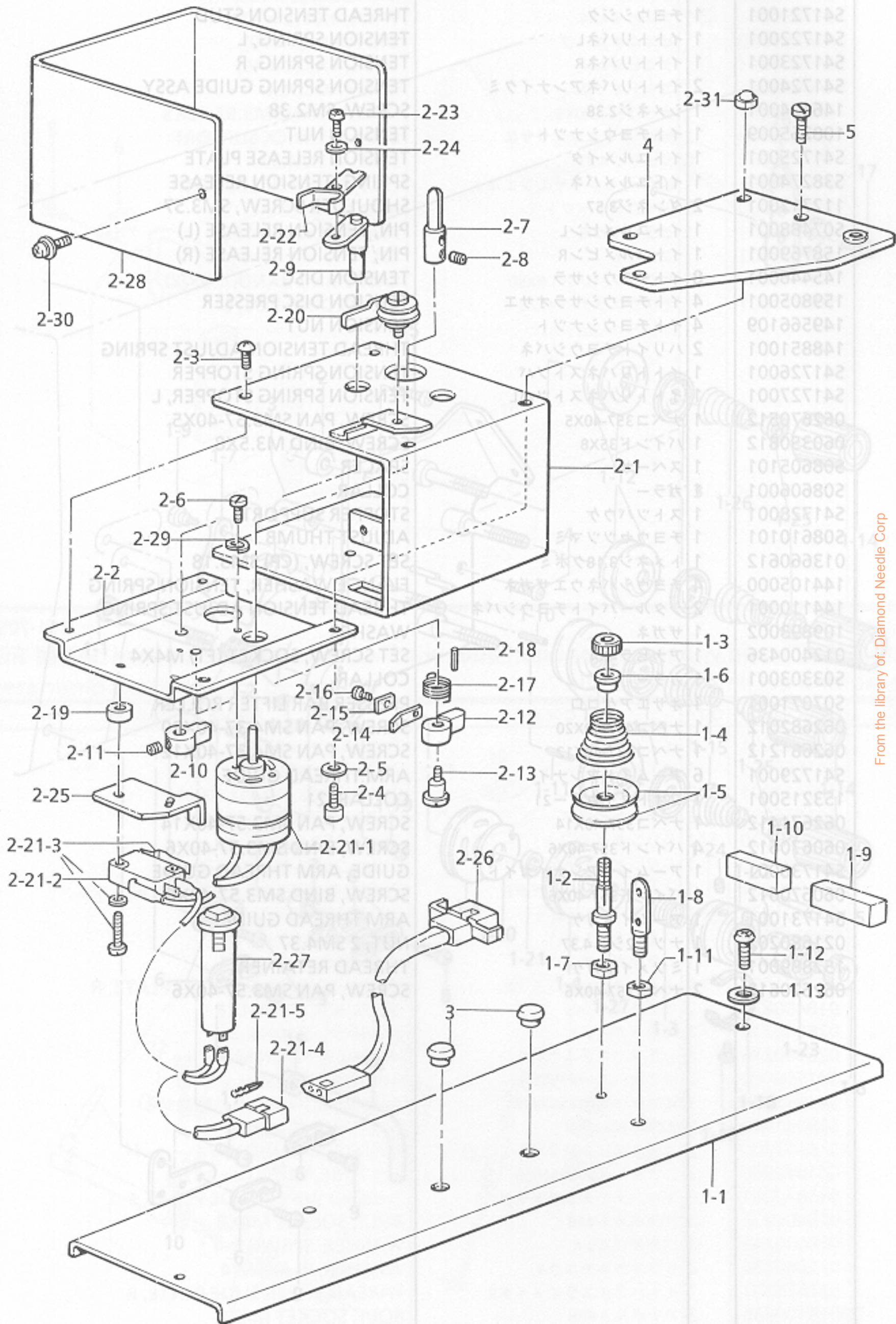

From the library of: Diamond Needle Corp

K. 糸巻関係 / Bobbin winder mechanism / Spuler / Mécanisme du bobineur  
/ Mecanismo del devanador de la canilla

REF.NO.	CODE	Q'TY	ヒンメイ	NAME OF PARTS	RM
1	S41859009	1	ウワブタクミ	TOP COVER ASSY	
1-1	S41860009	1	ウワブタ	TOP COVER	
1-2	159574101	1	イトチヨウシボウ	TENSION STUD	
1-3	100136001	1	イトチヨウシナツト	TENSION NUT	
1-4	144110001	1	シタルーパイトチヨウシバネ	THREAD TENSION ADJUST SPRING	
1-5	145446001	2	イトチヨウシサラ	TENSION DISC	
1-6	144105000	1	チヨウシバネウエザガネ	FLANGE WASHER, TENSION SPRING	
1-7	021680202	1	ナツト2シユ4.37	NUT, 2 SM4.37	
1-8	141590001	1	イトトオシボウ	THREADING BAR, U	
1-9	S41861000	1	クツシヨンL	CUSHION, L	
1-10	S41862000	1	クツシヨンS	CUSHION, S	
1-11	100022004	2	ナツト5.95	NUT, SM5.95	
1-12	062681212	3	ナベコ437-40X12	SCREW, PAN SM4.37-40X12	
1-13	025680232	3	ヒラザガネチユウ4.37	WASHER, PLAIN M 4.37	
2	S41863009	1	イトマキソウチクミ	BOBBIN WINDER ASSY	
2-1	S31961009	1	イトマキベース	BOBBIN WINDER BASE	
2-2	S39902001	1	イトマキモータシジイタ	BOBBIN WINDER MOTOR SUPPORT PLATE	
2-3	008300604	2	+トラスコ3X6	SCREW, TRUSS M3X6	
2-4	018401236	2	アナボルト4X12	BOLT, SOCKET M4X12	
2-5	110735002	2	ザガネ	WASHER	
2-6	S35032101	2	シメネジ2.6X5.5	SCREW, M2.6X5.5	
2-7	S39903001	1	イトマキジク	BOBBIN WINDER SHAFT	
2-8	014300332	2	アナクボミ3X3	SET SCREW, SOCKET (CP) M3X3	
2-9	154024001	1	ボビンオサエ	BOBBIN PRESSER	
2-10	154092001	1	イトマキツメダンツキ	BOBBIN WINDER CLAW	
2-11	014680422	2	アナトメネジ4.37クボミ	SET SCREW, SOCKET (CP) SM4.37	
2-12	152361001	1	イトマキレバー	BOBBIN WINDER LEVER	
2-13	152362001	1	イトマキダンネジ	BOBBIN WINDER SHOULDER SCREW	
2-14	111942001	1	イタバネ	SPRING, PLATE	
2-15	111943001	1	イタバネザガネ	WASHER	
2-16	060660512	1	バインド318-40X5	SCREW, BIND SM3.18-40X5	
2-17	152363001	1	ネジリバネA	TWIST SPRING, A	
2-18	047301042	1	スプリングピン	PIN, SPRING ROLL AW3	
2-19	152364001	2	カラー	COLLAR	
2-20	146197001	1	イトツカミクミ	THREAD CLAMP ASSY	
2-21	S39847001	1	イトマキモータクミ	BOBBIN WINDER MOTOR ASSY	
2-21-1	S39908000	1	イトマキモータ	BOBBIN WINDER MOTOR	
2-21-2	152507000	1	マイクロスイッチD	MICRO SWITCH, D	
2-21-3	152508000	1	マイクロアクチュエータ	MICRO ACTUATOR	
2-21-4	152509000	1	ナイロンコネクタE	NYLON CONNECTOR, E	
2-21-5	552851001	2	ピンターミナル#1854	TERMINAL PIN, #1854	
2-22	152645001	1	ボビンオサエイタ	BOBBIN HOLD PLATE	
2-23	062300616	1	ナベコM3X6	SCREW, PAN M3X6	
2-24	025030236	1	ヒラザガネチユウ3	WASHER, PLAIN M 3	
2-25	158597001	1	イトマキストツパー	BOBBIN WINDER STOPPER	
2-26	S21103000	1	イトマキハーネスC	BOBBIN WINDER HARNESS, C	
2-27	S16669000	1	プロテクタ0.5A	PROTECTOR, 0.5A	
2-28	S31960009	1	イトマキカバー	BOBBIN WINDER COVER	
2-29	028260242	2	バネザガネ2-2.6	WASHER, SPRING 2-2.6	
2-30	052300606	2	ナベコバネヒラ3x6	SCREW, PAN (S/P WASHER) M3X6	
2-31	S00505001	2	ロツカクフクロナツトM4	NUT, CAP M4	
30	104450109	2	ゴムセン8	RUBBER CAP, 8	
41	S41864009	1	イトマキソウチトリツケイタ	SETTING PLATE, BOBBIN WINDER ASSY	
52	106629002	2	シメネジ4.37	SCREW, SM4.37	
43	S41737001	1	ハリイタ	NEEDLE PLATE	
44	S38016001	1	イトキリレンカン	THREAD TRIMMER CONNECTING ROD	
45	S10205001	1	イドウハクミ	MOVABLE KNIFE ASSY	
46	S10208001	1	イドウハカンザ	WASHER, MOVABLE KNIFE	<t=0.4>
46	S10208002	1	イドウハカンザ	WASHER, MOVABLE KNIFE	<t=0.5>

From the library of: Diamond Needle Corp

L. 糸切り関係 / Thread trimmer mechanism / Fadenabschneidevorrichtung / Mécanisme de coupe-fil / Mecanismo de la cortadura de hiros

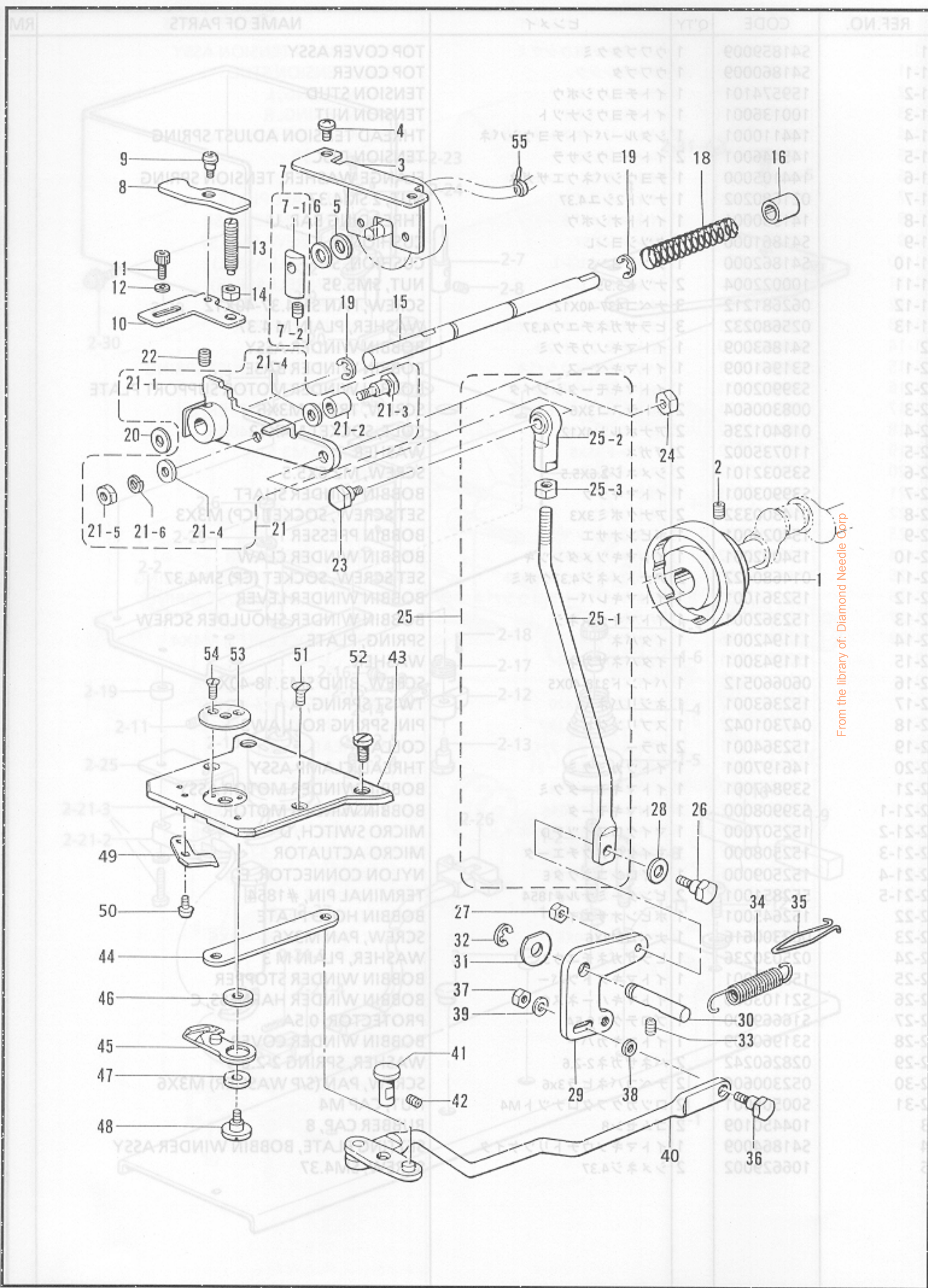

From the library of: Diamond Needle Corp

L. 糸切り関係 / Thread trimmer mechanism / Fadenabschneidevorrichtung  
 / Mécanisme de coupe-fil / Mecanismo de la cortadura de hiros

REF.NO.	CODE	Q'TY	ヒンメイ	NAME OF PARTS	RM
16	S38001001	1	イトキリカム <t=0.6>	THREAD TRIMMER CAM <t=0.6>	
27	014770622	2	アナトメネジ6.35クボミ	SET SCREW, SOCKET (CP) SM6.35	
38	S38002001	1	ソレノイドトリツケイタ	SOLENOID SET PLATE	
49	060680712	2	バインド437-40X7	SCREW, BIND SM4.37-40X7	
50	154599000	1	ソレノイドクツシヨン	SOLENOID CUSHION	
61	S02652001	1	ザガネ	WASHER	
72	S23836001	1	ソレノイドレバークミ	SOLENOID LEVER ASSY	
7-1	S02654001	1	ソレノイドレバー	SOLENOID LEVER	
7-2	014680622	1	アナトメネジ4.37クボミ	SET SCREW, SOCKET (CP) SM4.37	
85	S38003001	1	クドウレバーオシレバー	PUSHING LEVER DRIVING LEVER	
9	145478101	1	ダンネジ4.76	SHOULDER SCREW, SM4.76	
10	S38004002	1	クドウレバーストツバ <記号2>	DRIVING LEVER STOPPER, H = 0.3 <Mark 2>	
10	S38004003	1	クドウレバーストツバ <記号3>	DRIVING LEVER STOPPER, H = 0.6 <Mark 3>	
10	S38004004	1	クドウレバーストツバ <記号4>	DRIVING LEVER STOPPER, H = 0.45 <Mark 4>	
11	018681022	2	アナボルト4.37X10	BOLT, SOCKET SM4.37X10	
12	025680132	2	ヒラザガネシヨウ4.37	WASHER, PLAIN S 4.37	
13	159905001	1	トメヌイチヨウセツネジ	ADJUST SCREW	
14	106147002	1	ナツト7.94	NUT, SM7.94	
15	S38005001	1	クドウレバーアンナイジク	DRIVING LEVER SHAFT	
16	231071001	1	メタル8X15	BUSH, 8X15	
18	S41734001	1	クドウジクモドシバネ	RETURN SPRING, DRIVING SHAFT	
19	048070342	2	トメワE7	RETAINING RING, E7	
20	154596000	1	イトキリカムレバークツシヨン	CUSHION	
21	S38006001	1	イトキリクドウレバークミ	THREAD TRIMMER DRIVING LEVER ASSY	
21-1	S38007001	1	イトキリクドウレバー	THREAD TRIMMER DRIVING LEVER	
21-2	153597001	1	シタイトサバキカラー	LOWER THREAD RETAINER COLLAR	
21-3	S30033001	1	ダンネジ3.57	SHOULDER SCREW, SM3.57	
21-4	148813001	2	ザガネ	WASHER	
21-5	106129002	1	ナツト3.57	NUT, SM3.57	
21-6	028350242	1	バネザガネ2-3.5	WASHER, SPRING 2-3.5	
22	014770622	1	アナトメネジ6.35クボミ	SET SCREW, SOCKET (CP) SM6.35	
23	S02354001	1	タマツギテダンネジB	SHOULDER SCREW, B	
24	100022005	1	ナツト5.95	NUT, SM5.95	
25	S38008001	1	イトキリロツドクミ	THREAD TRIMMER ROD ASSY	
25-1	S38009001	1	イトキリロツド	THREAD TRIMMER ROD	
25-2	S07512001	1	タマツギテRクミ	ROUND JOINT ASSY, R	
25-3	100022005	1	ナツト5.95	NUT, SM5.95	
26	110233001	1	ダンネジ4.76	SHOULDER SCREW, SM4.76	
27	110161004	1	ナツト4.76	NUT, SM4.76	
28	109893002	1	ザガネ	WASHER	
29	S38010001	1	イトキリレバー	THREAD TRIMMER LEVER	
30	S10195001	1	イトキリレバージク	LEVER SHAFT	
31	110367001	1	ザガネ	WASHER, PLAIN SPECIAL 8	
32	048060342	1	トメワE6	RETAINING RING, E6	
33	014760622	1	アナトメネジ5.95	SET SCREW, SOCKET SM5.95	
34	S11170001	1	ヒキバネ	SPRING	
35	158940001	1	バネカケ	SPRING HOOK	
36	110233001	1	ダンネジ4.76	SHOULDER SCREW, SM4.76	
37	110161004	1	ナツト4.76	NUT, SM4.76	
38	153484001	1	ザガネ4.76	WASHER, PLAIN 4.76	
39	025680232	1	ヒラザガネチユウ4.37	WASHER, PLAIN M 4.37	
40	S41735001	1	レンカンレバークミ	CONNECTING ROD LEVER ASSY	
41	S10202101	1	レンカンレバージク	CONNECTING ROD LEVER SHAFT	
42	014680422	1	アナトメネジ4.37クボミ	SET SCREW, SOCKET (CP) SM4.37	
43	S41737001	1	ハリイタ	NEEDLE PLATE	
44	S38016001	1	イトキリレンカン	THREAD TRIMMER CONNECTING ROD	
45	S10205001	1	イドウハクミ	MOVABLE KNIFE ASSY	
46	S10208001	1	イドウハカンザ <t=0.4>	WASHER, MOVABLE KNIFE <t=0.4>	
46	S10208002	1	イドウハカンザ <t=0.5>	WASHER, MOVABLE KNIFE <t=0.5>	

From the library of: Diamond Needle Corp

L. 糸切り関係 / Thread trimmer mechanism / Fadenabschneidevorrichtung  
 / Mécanisme de coupe-fil / Mecanismo de la cortadura de hiros

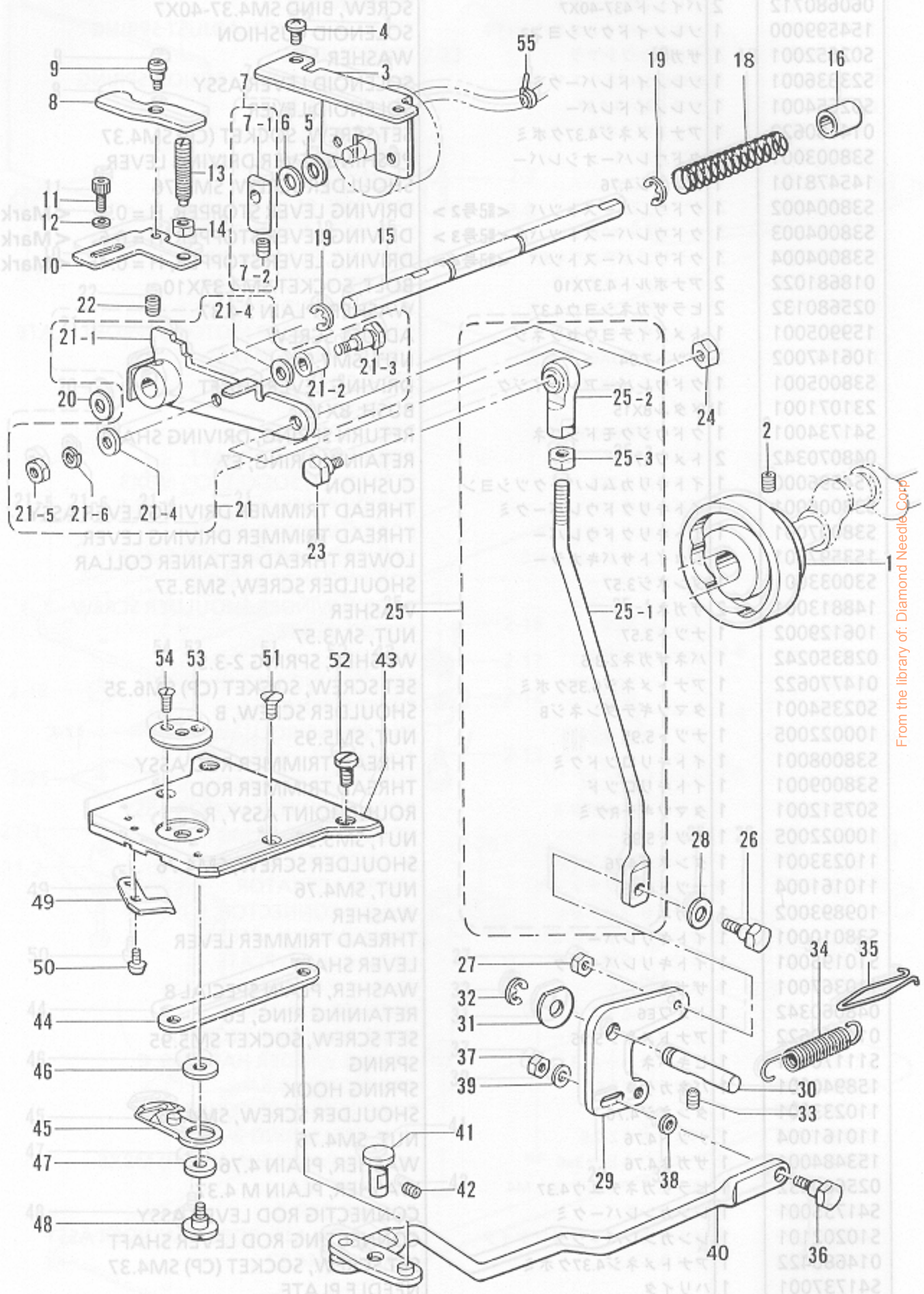

From the library of: Diamond Needle Corp

<f=0.4>  
 <f=0.2>

<f=0.4>  
 <f=0.2>

L. 糸切り関係 / Thread trimmer mechanism / Fadenabschneidevorrichtung  
 / Mécanisme de coupe-fil / Mecanismo de la cortadura de hiros

REF.NO.	CODE	Q'TY	ヒンメイ	NAME OF PARTS	RM
46	S10208003	1	イドウハカンザ <t=0.6>	WASHER, MOVABLE KNIFE PLATE <t=0.6>	
47	S00705001	1	イドウハカラー	MOVABLE KNIFE COLLAR	
48	S10209101	1	シメネジ4.37	SCREW, SM4.37	
49	S41738001	1	コテイハ	FIXED KNIFE	
50	111140002	2	シメネジ2.38	SCREW, SM2.38	
51	100032004	2	サラネジ4.37	SCREW, FLAT SM4.37	
52	153208002	2	シメネジ4.37	SCREW, SM4.37	
53	S10212101	1	ハリアナイタE	NEEDLE HOLE PLATE, E	
54	100360003	2	サラネジ2.38	SCREW, FLAT SM2.38	
55	228475000	1	ケツソクバンド1.9X80	FASTENING BAND, 1.9X80	

REF.NO.	CODE	Q'TY	ヒンメイ	NAME OF PARTS	RM
1	S41741000	1	ホウコウセンサイタ	DIRCTION SENSOR PLATE	
2	S41742000	1	ウワジクセンサイタ	UPPER SHAFT SENSOR PLATE	
3	062300512	2	ナベコ3X5	SCREW, PAN M3X5	
4	062680812	1	ナベコ4.37-40X8	SCREW, PAN SM4.37-40X8	

From the library of: Diamond Needle Corp

M. 糸締メ関係 / Thread nipper mechanism / Fadenspannvorrichtung / Mécanisme de pince-fil / Mecanismo de la mordaza para hilo

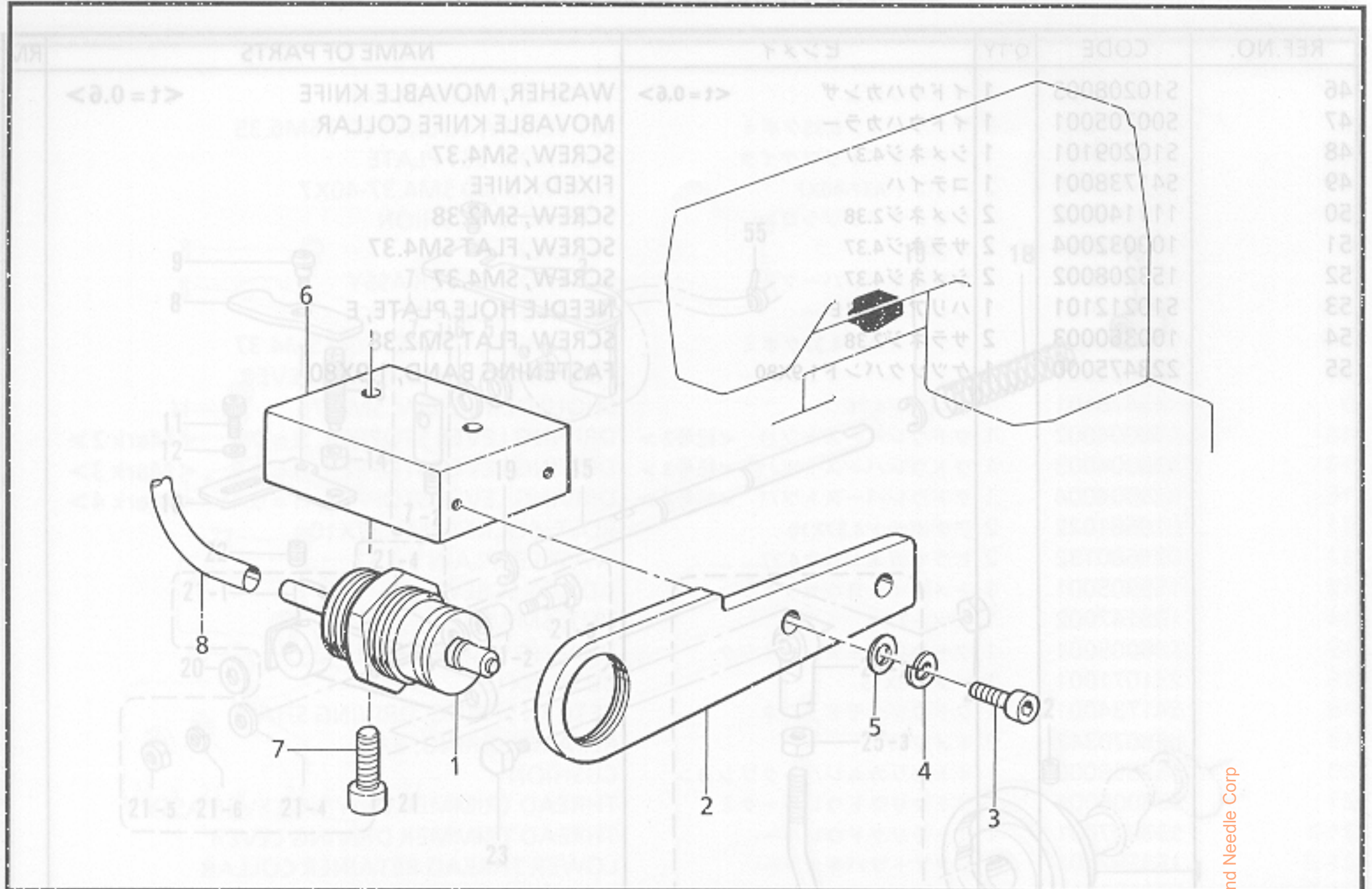

151-705-406

N. 針位置検出器関係 / Synchronizer / Synchronisator / Synchronisateur / Sincronizador

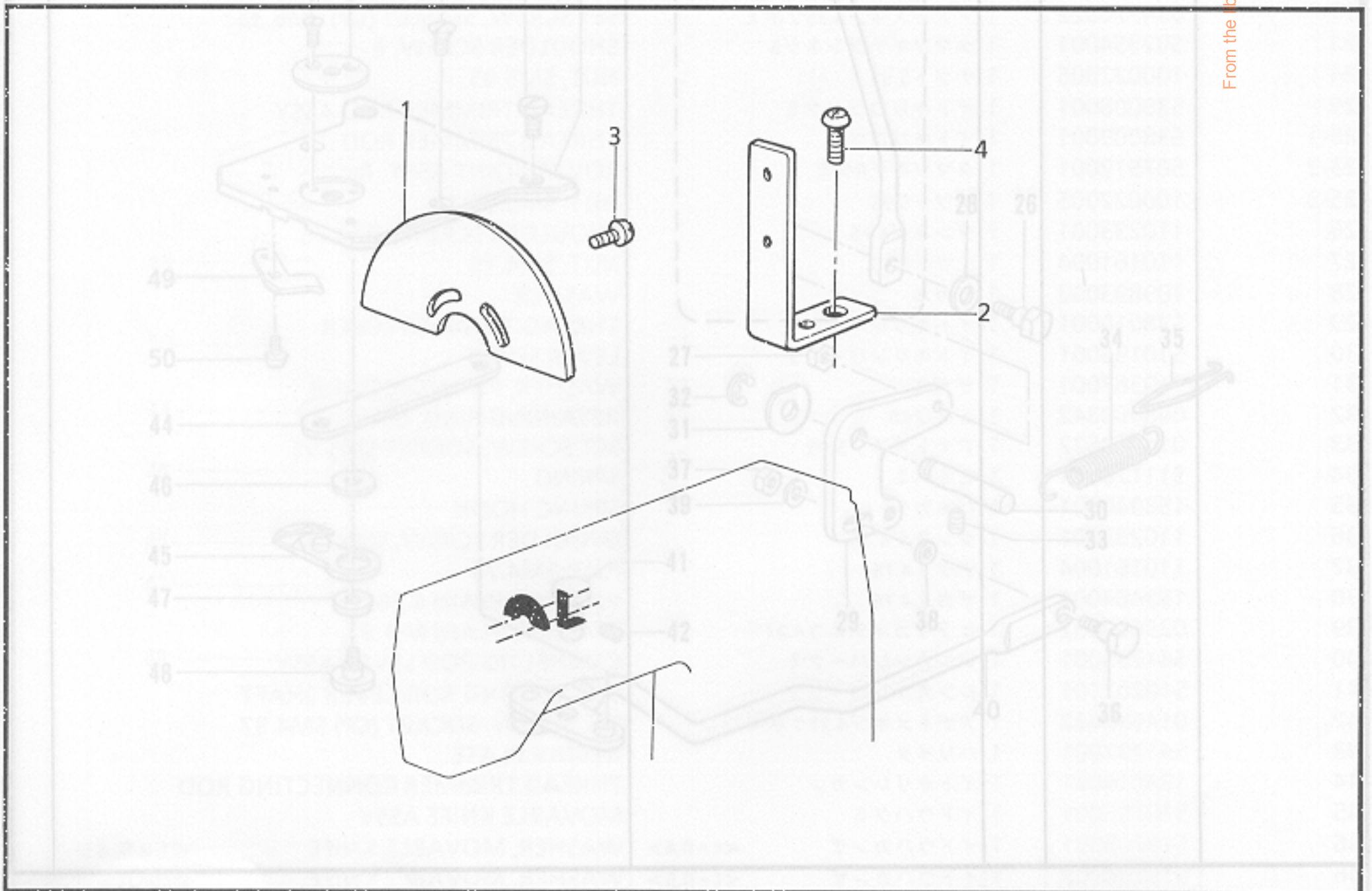

118-705-501

From the library of: Diamond Needle Corp

M. 糸締メ関係 / Thread nipper mechanism / Fadenspannvorrichtung / Mécanisme de pince-fil / Mecanismo de la mordaza para hilo

REF.NO.	CODE	Q'TY	ヒンメイ	NAME OF PARTS	RM
1	S41874000	1	シリンダクミ	CYLINDER ASSY	
2	S41877001	1	イトユルメシリンダイタ	THREAD RELEASE CYLINDER PLATE	
3-1	018501436	2	アナボルト5X14	BOLT, SOCKET M5X14	
4-1-1	028050246	2	バネザガネ2-5	WASHER, SPRING 2-5	
5-1-2	025050236	2	ヒラザガネチユウ5	WASHER, PLAIN M 5	
6-2	S41878001	1	イトユルメダイ	THREAD RELEASE BASE ASSY, B	
7-2-1	018501636	2	アナボルト5X16	BOLT, SOCKET M5X16	
8-2-2	S11440004	1	エアーチューブ	AIR TUBE, 4 (L = 1750)	
1-2-3	S112566000	1	ヒューズC	FUSE C, 2A	
2	0A5400806	4	ナベザクミ4X8D8	SCREW, PAN (S/P WASHER) M4X8	
3	S40445009	1	シワッパコネ	CONTROL BOX COVER ASSY	
3-1	S40445000	1	LEDモジュール	LCD MODULE	
3-2	S40445001	4	シメジ1.59	SCREW, SM1.59	
3-3	S40445000	1	インバータ	INVERTER	
3-4	S40451001	1	パネルキバ	PANEL PCB ASSY	
3-5	S40451000	1	パネルインバ	INVERTER HARNESS, PANEL	
3-6	0A5300605	1	ナベザクミ3X6D8	SCREW, PAN (S/P WASHER) M3X6	
3-7	0A5301005	1	ナベザクミ3X6D8	SCREW, PAN (S/P WASHER) M3X6	
4	S40451009	1	ソウサハ	STAND ASSY, OPERATION BOX	
4-1	S40451009	8	ソウサハ	STAND, OPERATION BOX	
4-2	S40451009	1	パネルヨコカバー	SIDE COVER, PANEL	
4-3	S107321003	1	タネジ4.76	SHOULDER SCREW, SM4.76	
4-4	S107017002	1	ミバネザガネ	WASHER, WAVE SPRING 6.45	
5	S40453000	1	ROM705/パネルクミ	ROM ASSY, 705 PANEL	
6	S40454004	4	トラスコ4X6	SCREW, TRUSS M4X6	
7	S40454000	1	パネルハーネス	PANEL HARNESS	
8	S40454000	1	ザガネ	WASHER	

151-705-406

N. 針位置検出器関係 / Synchronizer / Synchronisator / Synchronisateur / Sincronizador

REF.NO.	CODE	Q'TY	ヒンメイ	NAME OF PARTS	RM
1	S41741000	1	ホウコウセンサイタ	DIRCTION SENSOR PLATE	
2	S41742000	1	ウワジクセンサイタ	UPPER SHAFT SENSOR PLATE	
3	062300512	2	ナベコ3X5	SCREW, PAN M3X5	
4	062680812	1	ナベコ437-40X8	SCREW, PAN SM4.37-40X8	
19	S41964000	1	ブツシュ	BUSHING	
20	S11763000	1	スパイラル1005	SPIRAL, 1005	
21	025060336	2	ヒラザガネダイ6	WASHER, PLAIN L 6	
22	028060246	2	バネザガネ2-6	WASHER, SPRING 2-6	
23	S121060206	1	ナット	NUT, 2 M6	



P. コントロールボックス関係 / Control box mechanism / Schaltkasten  
 / Mécanisme du boîtier de contrôle / Mecanismo de la caja de controles

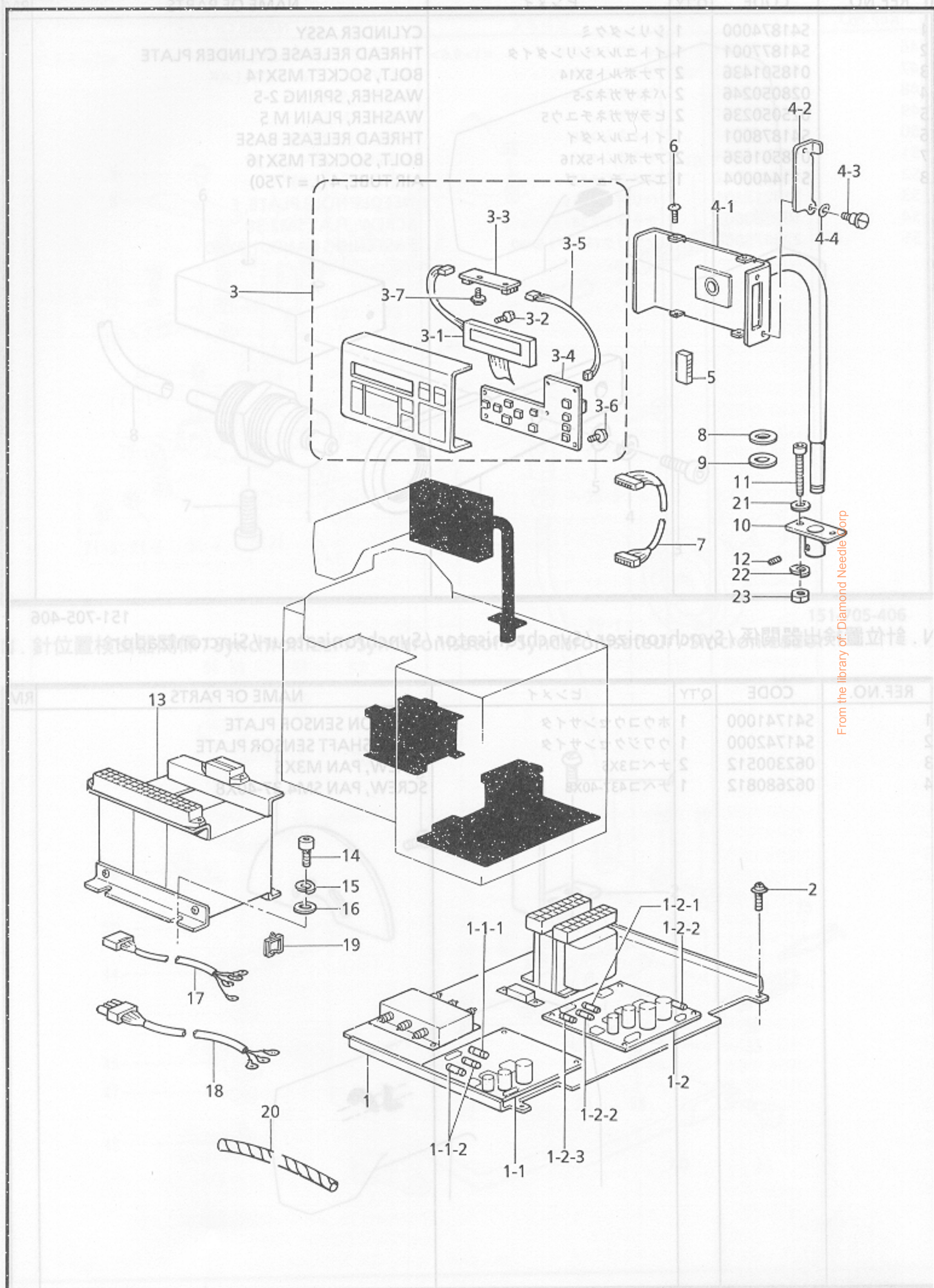

From the library of: Diamond Needle Corp

P. コントロールボックス関係 / Control box mechanism / Schaltkasten  
 / Mécanisme du boîtier de contrôle / Mecanismo de la caja de controles

REF.NO.	CODE	Q'TY	ヒンメイ	NAME OF PARTS	RM
1	S40438001	1	デンゲンユニットクミ	POWER SUPPLY UNIT ASSY	
1-1	S40439001	1	デンゲンキバンAクミ	POWER CIRCUIT BOARD ASSY, A	
1-1-1	215769001	1	カンヒューズ3A	FUSE, 3A	
1-1-2	152566000	2	ヒューズC	FUSE C, 2A	
1-2	S40440001	1	デンゲンキバンBクミ	POWER CIRCUIT BOARD ASSY, B	
1-2-1	153242000	1	ヒューズ6A	FUSE, 6A	
1-2-2	157219000	2	カンヒューズ5A-D	FUSE 5A-D	
1-2-3	152566000	1	ヒューズC	FUSE C, 2A	
2	0A5400806	4	+ナベザクミ4X8DB	SCREW, PAN (S/P WASHER) M4X8	
3	S40445009	1	ソウサハコフタクミ	CONTROL BOX COVER ASSY	
3-1	S40447000	1	LCDモジュール	LCD MODULE	
3-2	154674001	4	シメネジ1.59	SCREW, SM1.59	
3-3	S40448000	1	インバータ	INVERTER	
3-4	S40511001	1	パネルキバンクミ	PANEL PCB ASSY	
3-5	S40455000	1	パネルインバータハーネス	INVERTER HARNESS, PANEL	
3-6	0A5300605	6	+ナベザクミ3X6DB	SCREW, PAN (S/P WASHER) M3X6	
3-7	0A5301005	3	+ナベザクミ3X6DB	SCREW, PAN (S/P WASHER) M3X6	
4 1-1	S40451009	1	ソウサハコスタンドクミ	STAND ASSY, OPERATION BOX	
4-1-2	S40452009	1	ソウサハコスタンド	STAND, OPERATION BOX	
4-2 3	S40499009	1	パネルヨコカバー	SIDE COVER, PANEL	
4-3 4	107321003	1	ダンネジ4.76	SHOULDER SCREW, SM4.76	
4-4 5	107017002	1	ナミバネザガネ	WASHER, WAVE SPRING 6.45	
5 1-6	S40453000	1	PROM705パネルクミ	PROM ASSY, 705 PANEL	
6 1-7	008400604	4	+トラスコ4X6	SCREW, TRUSS M4X6	
7 2	S40454000	1	パネルハーネス	PANEL HARNESS	
8 3	S10409002	1	ザガネ	WASHER	
9 5	S10408000	1	ゴムシート	RUBBER SHEET	
10	S15056001	1	ハコササエホルダ	BOX HOLDER	
11	018065036	2	アナボルト6X50	BOLT, SOCKET M6X50	
12	014760622	1	アナトメネジ5.95	SET SCREW, SOCKET SM5.95	
13	S40504000	1	3ソウトランス705	TANSFORMER, THREE PHASE 705	
14	018081236	4	アナボルト8X12	BOLT, SOCKET M8X12	
15	028080246	4	バネザガネ2-8	WASHER, SPRING 2-8	
16	025080236	4	ヒラザガネチユウ8	WASHER, PLAIN M 8	
17	S40505000	1	デンゲンハーネスHA	POWER SUPPLY HARNESS, HA	
18	S41969000	1	デンゲンハーネスHB	POWER SUPPLY HARNESS, HB	
19	S41964000	1	ブツシュ	BUSHING	
20	S11763000	1	スパイラル100S	SPIRAL, 100S	
21	025060336	2	ヒラザガネダイ6	WASHER, PLAIN L 6	
22	028060246	2	バネザガネ2-6	WASHER, SPRING 2-6	
23	021060206	2	2シユナツト6	NUT, 2 M6	
59	S41935000	1	エアホース0425S035B	AIR TUBE, 0425S (L = 350)	
60	S41935000	1	エアホース0425S035B	AIR TUBE, 0425S (L = 350)	
61	S41935000	1	エアホース0425S035B	AIR TUBE, 0425S (L = 350)	
62	S41935000	1	エアホース0425S035B	AIR TUBE, 0425S (L = 350)	
63	S41935000	1	エアホース0425S035B	AIR TUBE, 0425S (L = 350)	
64	S41941000	1	エアホース0425S124B	AIR TUBE, 0425S (L = 124)	
65	S41706000	1	エアホース0425S124B	AIR TUBE, 0425S (L = 124)	
66	S41935000	1	エアホース0425S035B	AIR TUBE, 0425S (L = 350)	
67	S41940000	1	エアホース0425S124B	AIR TUBE, 0425S (L = 124)	
68	S41938000	1	エアホース0425S124B	AIR TUBE, 0425S (L = 124)	
69	S41939000	1	エアホース0425S124B	AIR TUBE, 0425S (L = 124)	
70	S14085008	2	ミニチュアユニオンY4	MINIATURE UNION, Y4	
71	S19557000	2	コガタユニオンワイ4	MINIATURE UNION, Y4	
72	S41916000	2	エアホース0425S022B	AIR TUBE, 0425S (L = 220)	
75	S14085001	2	ミニチュアユニオンY4	MINIATURE UNION, Y4	
77	S33870001	1	エアチューブ	AIR TUBE, 4 (L = 82)	
78	S19557000	1	コガタユニオンワイ4	AIR TUBE, 4 (L = 840) BLACK	
79	S41935000	1	エアホース0425S035B	AIR TUBE, 0425S (L = 350)	

From the library of: Diamond Needle Corp

Q. 空圧関係 / Air pressure mechanism / Luftdruck / Mécanisme de la pression d'air  
 / Mecanismo de la presión de aire

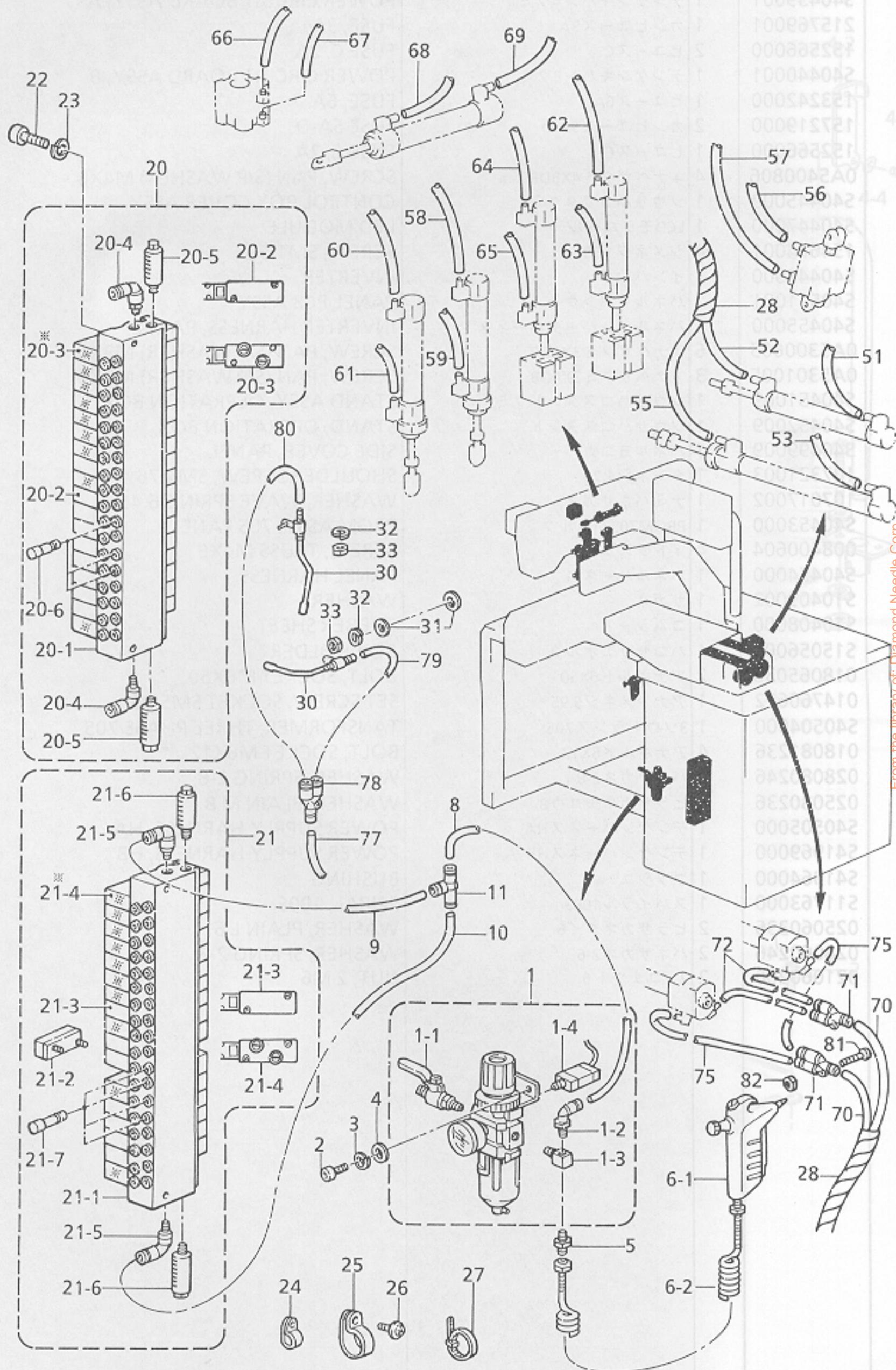

From the library of: Diamond Needle Corp

Q. 空圧関係 / Air pressure mechanism / Luftdruck / Mécanisme de la pression d'air / Mecanismo de la presión de aire

REF.NO.	CODE	Q'TY	ヒンメイ	NAME OF PARTS	RM
10	S41641000	1	フィルターレギュレータクミ	FILTER REGULATOR ASSY	
1-1	S09231000	1	ボールバルブ1/4	BALL VALVE, 1/4	
1-2	S31169000	1	エルボユニオン8	ELBOW UNION, 8	
1-3	153252000	1	PTチーズ	PT-JOINT	
1-4	S17028000	1	アツリヨクスイッチ	PRESSURE SWITCH	
2	018061222	2	アナボルト6X12	BOLT, SOCKET M6X12	
30	028060242	2	バネザガネ2-6	WASHER, SPRING 2-6	
40-1	025060232	2	ヒラザガネチユウ6	WASHER, PLAIN M 6	
50-2	S04891000	1	チユウカンニツブル1/4	MIDDLE NIPPLE, 1/4	
60-3	S06857000	1	エアガンクミ	AIR GUN ASSY	
6-14	S06858000	1	エアガン	AIR GUN	
6-25	S06859000	1	カールホース	CURL TUBE	
80-6	S31764000	1	エアチューブ8X280	AIR TUBE, 8 (L = 280)	
9	S39113000	1	エアホース0806S030B	AIR TUBE, 0806S (L = 300)	
10	S41637000	1	エアホース0806S024B	AIR TUBE, 0806S (L = 240)	
11	S31170000	1	チーズ8	T-JOINT, 8	
21	S41631000	1	バルブユニット17クミ	VALVE UNIT ASSY, 17	
21-1	S41633000	1	マニホールド18	MANIFOLD, 18	
21-2	S41634000	1	ブランピングプレート	BLANKING PLATE	
21-3	S39115000	8	バルブVQZ1151-5	VALVE, VQZ1151-5	
21-4	S39116000	9	バルブVQZ1151S-5	VALVE, VQZ1151S-5	
21-5	S14159000	2	エルボ1/8-8	ELBOW, 1/8-8	
21-6	140682001	2	サイレンサン	SILENCER	
21-7	S04897000	4	プラグ4	PLUG, 4	
22	018503036	2	アナボルト5X30	BOLT, SOCKET M5X30	
23	028050246	2	バネザガネ2-5	WASHER, SPRING 2-5	
25	554482000	1	コードホルダ#12	CORD HOLDER, 12N	
26	0A5401006	1	ナベザクミ4X10DB	SCREW, PAN (S/P WASHER) M4X10	
27	S04557000	20	バンタイPLTIM	BAND, PLTIM	
28	S11763000	2	スパイラル100S	SPIRAL, 100S	
30	S23747001	2	エアブロークミ	AIR BLOWER ASSY	
31	025050236	2	ヒラザガネチユウ5	WASHER, PLAIN M 5	
32	028050246	2	バネザガネ2-5	WASHER, SPRING 2-5	
33	021500106	2	1シユナツト5	NUT, 1 M5	
51	S41938000	1	エアホース0425S105B	AIR TUBE, 0425S (L = 1050)	
52	S41938000	1	エアホース0425S105B	AIR TUBE, 0425S (L = 1050)	
53	S41939000	1	エアホース0425S	AIR TUBE, 0425S (L = 1120)	
55	S41636000	1	エアホース0425S100B	AIR TUBE, 0425S (L = 1000)	
56	S08176000	1	エアホース4-0	AIR TUBE, 4-0 (L = 980)	
57	S08176000	1	エアホース4-0	AIR TUBE, 4-0 (L = 980)	
58	S41943000	1	エアホース0425S145B	AIR TUBE, 0425S (L = 1450)	
59	S31706000	1	エアチューブ4X1510	AIR TUBE, 4 (L = 1510)	
60	S41943000	1	エアホース0425S145B	AIR TUBE, 0425S (L = 1450)	
61	S31706000	1	エアチューブ4X1510	AIR TUBE, 4 (L = 1510)	
62	S41941000	1	エアホース0425S137B	AIR TUBE, 0425S (L = 1370)	
63	S41943000	1	エアホース0425S145B	AIR TUBE, 0425S (L = 1450)	
64	S41941000	1	エアホース0425S137B	AIR TUBE, 0425S (L = 1370)	
65	S31706000	1	エアチューブ4X1510	AIR TUBE, 4 (L = 1510)	
66	S41940000	1	エアホース0425S124B	AIR TUBE, 0425S (L = 1240)	
67	S41940000	1	エアホース0425S124B	AIR TUBE, 0425S (L = 1240)	
68	S41938000	1	エアホース0425S105B	AIR TUBE, 0425S (L = 1050)	
69	S41939000	1	エアホース0425S	AIR TUBE, 0425S (L = 1120)	
70	S14085008	2	エアチューブ	AIR TUBE, 4X1160	
71	S19557000	2	コガタユニオンワイ4	MINIATURE UNION, Y4	
72	S41916000	2	エアホース0425S022B	AIR TUBE, 0425S (L = 220)	
75	S14085001	2	エアチューブ	AIR TUBE, 4 (L = 82)	
77	S33870001	1	エアチューブ	AIR TUBE, 4 (L = 840) BLACK	
78	S19557000	1	コガタユニオンワイ4	MINIATURE UNION, Y4	
79	S41935000	1	エアホース0425S035B	AIR TUBE, 0425S (L = 350)	

From the library of: Diamond Needle Corp

Q. 空圧関係 / Air pressure mechanism / Luftdruck / Mécanisme de la pression d'air / Mecanismo de la presión de aire

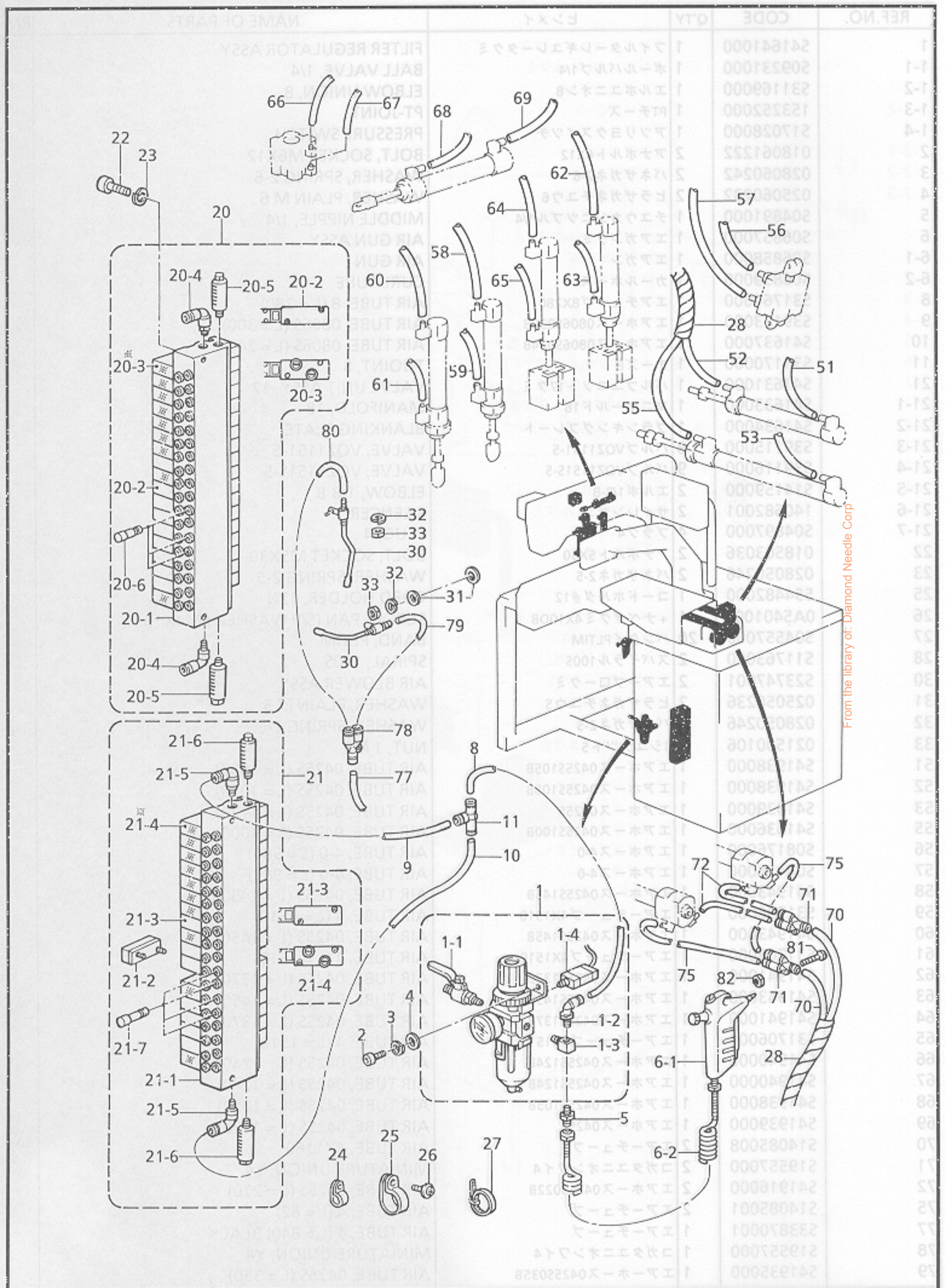

From the library of: Diamond Needle Corp

Q. 空圧関係 / Air pressure mechanism / Luftdruck / Mécanisme de la pression d'air / Mecanismo de la presión de aire

REF.NO.	CODE	Q'TY	ヒンメイ	NAME OF PARTS	RM
80	S41937000	1	エア-ホース0425S060B	AIR TUBE, 0425S (L = 600)	
81	062302506	1	ナベコ3X25	SCREW, PAN M3X25	
82	021300206	1	2シユナツト3	NUT, 2 M3	
<ベルトスラック装置用>					
20	S41632000	1	バルブユニット18クミ	VALVE UNIT ASSY, 18	
20-1	S41633000	1	マニホールド18	MANIFOLD, 18	
20-2	S39115000	9	バルブVQZ1151-5	VALVE, VQZ1151-5	
20-3	S39116000	9	バルブVQZ1151S-5	VALVE, VQZ1151S-5	
20-4	S14159000	2	エルボ1/8-8	ELBOW, 1/8-8	
20-5	140682001	2	サイレンサン	SILENCER	
20-6	S04897000	3	プラグ4	PLUG, 4	
4-2	S00000000	1	圧力センサハーネス	PRESSURE SENSOR HARNESS	
4-3	S00000000	1	圧力スイッチハーネス	PRESSURE SWITCH HARNESS	
4-4	S41960000	1	圧力センサーリブハーネス	SENSOR HARNESS, LOOP FOLD	
5	S46837000	1	圧力センサーリブ	SENSOR BRACKET	
6	062303106	6	ナベコM3X10	SCREW, PAN M3X10	
7	S0464000	1	電源ハーネスMA	POWER SUPPLY HARNESS, MA	
8	S04027000	2	ACDR-POWERハーネス	ACDR-POWER SUPPLY HARNESS	
9	S04026000	2	ACDR-SIGNALハーネス	ACDR-SIGNAL HARNESS	
10	S04025000	2	ACDR-POWER SUPPLY HARNESS	ACDR-POWER SUPPLY HARNESS	
11	S04024000	2	ACDR-POWER SUPPLY HARNESS	ACDR-POWER SUPPLY HARNESS	
12	S04023000	1	ファンハーネス	FAN SUPPLY HARNESS	
13	S41187000	1	電源ハーネス	POWER SUPPLY HARNESS	
14	S40467000	1	ROMメイン	ROM, XY1	
15	S40470000	1	ROMXYメイン	ROM, XY1	
16	S40457000	1	ROMXYモータ	ROM, XY2	
17	S40472000	1	スタートスイッチハーネス	START SWITCH HARNESS	
18	S43402000	1	スタートスイッチ	START SWITCH	
19	S40462000	1	センサー	SENSOR, GL-12L	
20-1	S40462000	1	センサー	SENSOR, GL-12L	
21	S40462000	1	センサー	SENSOR, GL-12L-A	
22	S40437000	1	センサー	SENSOR BRACKET	
23	062300806	2	ナベコ3X8	SCREW, PAN M3X8	
24	S13216000	1	クランプNK-2N	CLAMP, NK-2N	
25	042540000	1	ナベコ3X8	SCREW, PAN (S/P WASHER) M3X8	
26	S40485001	1	スタートスイッチ	HAND START SWITCH ASSY	
27	S40449001	1	スイッチベース	SWITCH BASE	
28	S20871001	1	スタートスイッチ	HAND SWITCH ASSY	
29	062301206	1	ナベコM3X10	SCREW, PAN (S/P WASHER) M3X10	
30	S40494001	1	スイッチ	SPRIG, SWITCH	
31	S32294001	1	ボルトソケットM4X35	BOLT, SOCKET M4X35	
32	154514001	1	スペーサ	SPACER	
33	021400216	1	ナット	NUT, 2 M4	
34	025040236	2	ワッシャー	WASHER, PLAIN M4	
35	121707002	2	ワッシャー	WASHER, PLAIN 4	
36	018400636	1	ボルトソケットM4X6	BOLT, SOCKET M4X6	
37	021400216	1	ナット	NUT, 2 M4	
38	S040743000	2	ナイロンクランプNK-3N	NYLON CLAMP, NK-3N	
39	062300612	2	ナベコM3X8	SCREW, BIND M3X8	
40	S41492002	1	スイッチレバー	SWITCH LEVER ASSY	
41	S40493001	1	スイッチレバー	SWITCH LEVER	
42	S40494000	1	スイッチキャップ	SWITCH CAP	
43	062301005	1	ナベコM3X10	SCREW, PAN M3X10	
44	021300303	1	ナット	NUT, 2 M3	
45	S07370102	1	スラストネジ	THRUSTER SCREW, SM 3.95	
46	153113001	1	スラストワッシャー	THRUST WASHER	
47	S03695001	1	ワッシャー	WASHER, PLAIN 6	

From the library of: Diamond Needle Corp

R1. 電装品関係 / Power supply equipment mechanism / Stromversorgung

/ Mécanisme de l'équipement en alimentation électrique

/ Mecanismo del equipo de alimentación de corriente

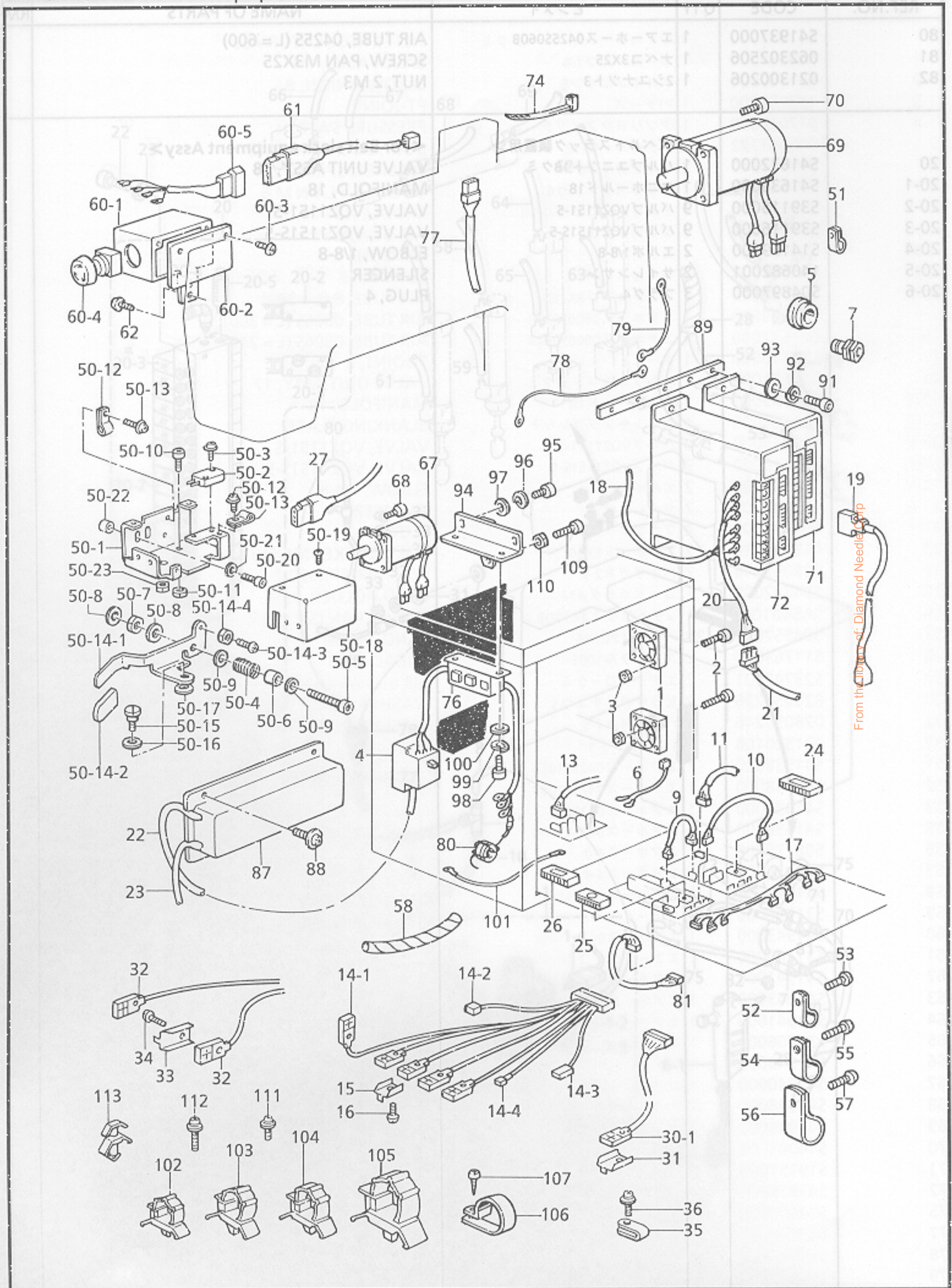

From the library of: Diamond Needle Corp

R1. 電装品関係 / Power supply equipment mechanism / Stromversorgung  
 / Mécanisme de l'équipement en alimentation électrique  
 / Mecanismo del equipo de alimentación de corriente

REF.NO.	CODE	Q'TY	ヒンメイ	NAME OF PARTS	RM
10-18	S16566000	2	クーリングファン	COOLING FAN	
20-19	S32294001	8	アナボルト4X35	BOLT, SOCKET M4X35	
30-20	021400206	8	2シユナツト4	NUT, 2 M4	
40-21	S38819000	1	ブレーカEA33/5	BREAKER, EA33/5	
50-22	S38820000	2	ブツシユ35	BUSHING, 35	
60-23	S10333000	2	ファンコード	FAN CORD	
7	152510000	3	コードブツシユ	CORD BUSH	
9	S40456000	1	RS-XYハーネス	RS-XY HARNESS	
10	S40457000	1	シンクロハーネス	SYNCHRONIZER HARNESS	
11	S40458000	2	ACDRハーネス	ACDR HARNESS	
13	S40460000	1	バルブハーネスクミ	VALVE HARNESS ASSY	
14	S40461000	1	センサクミ	SENSOR ASSY	
14-1	S40462000	6	センサGL-12L	SENSOR, GL-12L	
14-2	S40500000	1	セットセンサハーネス	SET SENSOR HARNESS	
14-3	S41961000	1	アツリヨクSWハーネス	PRESSURE SWITCH HARNESS	
14-4	S41963000	1	ループオリSWハーネス	SWITCH HARNESS, LOOP FOLD	
15	S40437000	6	センサカナグ	SENSOR BRACKET	
16	062301006	6	ナベコ3X10	SCREW, PAN M3X10	
17	S40464000	1	デンゲンハーネスMA	POWER SUPPLY HARNESS, MA	
18	S40467000	2	ACDR-POWハーネス	ACDR-POWER SUPPLY HARNESS	
19	S40468000	2	ACDR-SIGハーネス	ACDR-SIGNAL HARNESS	
20	S40508000	2	ACDRデンゲンハーネスA	ACDR-POWER SUPPLY HARNESS, A	
21	S41972000	2	ACDRデンゲンハーネスB	ACDR-POWER SUPPLY HARNESS, B	
22	S40510000	1	デンゲンハーネスFDF	POWER SUPPLY HARNESS, FDF	
23	S41967000	1	デンゲンハーネスFA	POWER SUPPLY HARNESS, FA	
24	S40469000	1	PROMメインクミ	PROM MAIN ASSY	
25	S40470000	1	PROMXYメイン	PROM, XY1	
26	S40471000	1	PROMXYモータ	PROM, XY2	
27	S40472000	1	スタートSWハーネス	START SWITCH HARNESS	
30	S43402000	1	ソウチスイツチ	SENSOR ASSY	
30-1	S40462000	1	センサGL-12L	SENSOR, GL-12L	
31	S40437000	1	センサカナグ	SENSOR BRACKET	
32	S40463000	2	センサGL-12L-A	SENSOR, GL-12L-A	
33	S40437000	2	センサカナグ	SENSOR BRACKET	
34	062300806	2	ナベコ3X8	SCREW, PAN M3X8	
35	S11816000	1	クランプNK-2N	CLAMP, NK-2N	
36	0A5400806	1	+ナベザクミ4X8DB	SCREW, PAN (S/P WASHER) M4X8	
50	S40485001	1	テモトスタートスイッチクミ	HAND START SWITCH ASSY	
50-1	S40449001	1	SWベース	SWITCH BASE	
50-2	S20871001	1	テモトスイッチクミ	HAND SWITCH ASSY	
50-3	0A5301405	2	ナベザクミ3X14DB	SCREW, PAN (S/P WASHER) M3X14	
50-4	S40491001	1	SWバネ	SPRING, SWITCH	
50-5	S32294001	1	アナボルト4X35	BOLT, SOCKET M4X35	
50-6	154514001	1	スパーサー	SPACER, PLAIN M4	
50-7	021400216	1	2シユナツト4	NUT, 2 M4	
50-8	025040236	2	ヒラザガネチユウ4	WASHER, PLAIN M 4	
50-9	102707002	2	ザガネ	WASHER, PLAIN 4	
50-10	018400636	1	アナボルト4X6	BOLT, SOCKET M4X6	
50-11	021400216	1	2シユナツト4	NUT, 2 M4	
50-12	S10243000	2	ナイロンクランプNK-3N	CORD HOLDER, NK-3N	
50-13	060300612	2	バインド M3X6	SCREW, BIND M3X6	
50-14	S40492001	1	SWレバークミ	SWITCH LEVER ASSY	
50-14-1	S40493001	1	SWレバー	SWITCH LEVER	
50-14-2	S40494000	1	SWキャツブ	SWITCH CAP	
50-14-3	062301005	1	ナベコ3X10	SCREW, PAN M3X10	
50-14-4	021300303	1	ナツト3シユ3	NUT, 3 M3	
50-15	S07370102	1	ダンネジ5.95	SHOULDER SCREW, SM5.95	
50-16	153113001	1	スラストザガネ	THRUST WASHER (WASHER) M4X16	
50-17	S03695001	1	ザガネ6	WASHER, PLAIN 6	

From the library of: Diamond Needle Corp.



R1 . 電装品関係 / Power supply equipment mechanism / Stromversorgung  
 / Mécanisme de l'équipement en alimentation électrique  
 / Mecanismo del equipo de alimentación de corriente

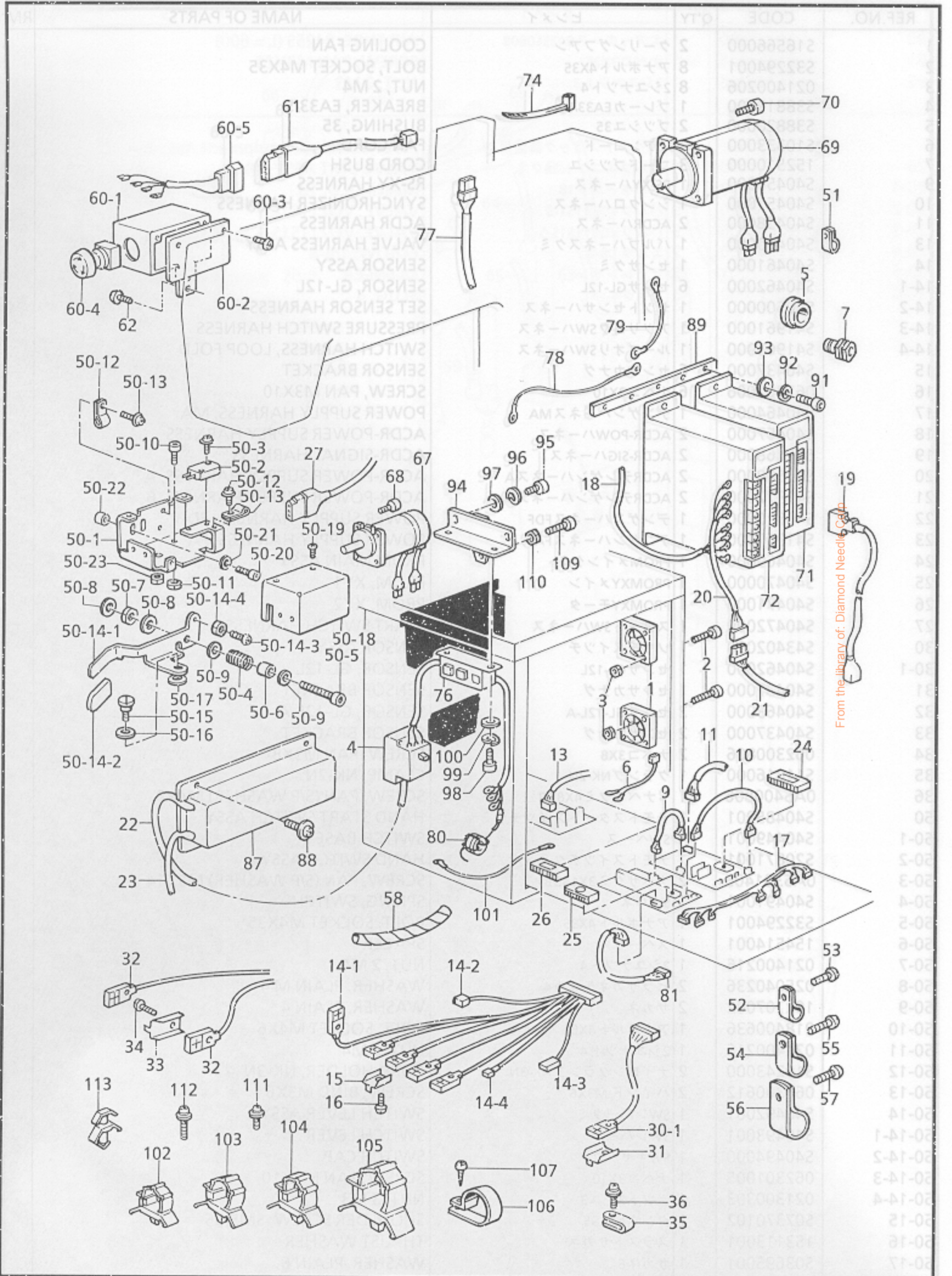

R1. 電装品関係 / Power supply equipment mechanism / Stromversorgung  
 / Mécanisme de l'équipement en alimentation électrique  
 / Mecanismo del equipo de alimentación de corriente

REF.NO.	CODE	Q'TY	ヒンメイ	NAME OF PARTS	RM
50-18	S40495001	1	SWカバー	SWITCH COVER	
50-19	008300604	6	+トラスコ3X6	SCREW, TRUSS M3X6	
50-20	018502036	2	アナボルト5X20	BOLT, SOCKET M5X20	
50-21	025050236	2	ヒラザガネチユウ5	WASHER, PLAIN M 5	
50-22	152863001	2	クツシヨンカラー	CUSHION COLLAR	
50-23	106588003	1	ナツト5.95	NUT, SM5.95	
51	149547000	1	コードオサエ	CORD HOLDER, 4N	
52	S00480000	2	コードホルダ#5	CORD HOLDER, 5N	
53	052400806	2	ナベコバネヒラ4X8	SCREW, PAN (S/P WASHER) M4X8	
54	525567000	1	コードホルダ#8	CORD HOLDER, 6N	
55-1	052400806	1	ナベコバネヒラ4X8	SCREW, PAN (S/P WASHER) M4X8	
56-2	554482000	1	コードホルダ#12	CORD HOLDER, 12N	
57	052400806	1	ナベコバネヒラ4X8	SCREW, PAN (S/P WASHER) M4X8	
58-1	S11763000	1	スパイラル100S	SPIRAL, 100S	
60	S40513009	1	EMロックSWクミ	EM-LOCK SWITCH ASSY	
60-1	S32111009	1	EMロックSWハコ	EM-LOCK SWITCH BOX	
60-2	S32112009	1	EMロックSWカバー	EM-LOCK SWITCH COVER	
60-3	008300604	2	+トラスコ3X6	SCREW, TRUSS M3X6	
60-4	S32335000	1	SW-AVS311N	SWITCH, AVS311N	
60-5	S40473000	1	EMロックSWハーネス	EM-LOCK SWITCH HARNESS	
61	S40474000	1	EMSWハーネス	EM-SWITCH HARNESS	
62	062710812	2	ナベコ476-32X8	SCREW, PAN SM4.76-32X8	
67	S40475000	1	ACサーボモータ100	AC-SERVO MOTOR, 100	
68	018301236	4	アナボルト3X12	BOLT, SOCKET M3X12	
69	S40476000	1	ACサーボモータ750	AC-SERVO MOTOR, 750	
70	018501636	4	アナボルト5X16	BOLT, SOCKET M5X16	
71	S40477000	1	ACサーボDR100	AC-SERVO, DR100	
72	S40478000	1	ACサーボDR750	AC-SERVO, DR750	
74	S04557000	20	バンタイPLTIM	BAND, PLTIM	
76	S40486000	1	デンゲンSWクミ	POWER SUPPLY SWITCH ASSY	
77	S40509000	1	イトマキハーネス	BOBBIN WINDER HARNESS	
78	S11733000	2	アースセン1700	GROUND WIRE, 1700	
79	S38145000	1	アースセン2	GROUND WIRE, 2	
80	S40497000	1	アースインダクタ	EARTH INDUCTER	
81	S40481000	1	イトキリエンチヨウハーネス	EXTENDED HARNESS, THR. TRIMMER	
87	S40503000	1	EMCBOXクミ	BOX ASSY, EMC	
88	0A5401006	4	+ナベザクミ4X10DB	SCREW, PAN (S/P WASHER) M4X10	
89	S41965001	2	ドライバササエイタ	DRIVER SUPPORT PLATE	
91	018401236	10	アナボルト4X12	BOLT, SOCKET M4X12	
92	028040246	10	バネザガネ2-4	WASHER, SPRING 2-4	
93	025040236	10	ヒラザガネチユウ4	WASHER, PLAIN M 4	
94	S41889001	1	SWトリツケイタ	SWITCH SETTING PLATE	
95	018400836	2	アナボルト4X8	BOLT, SOCKET M4X8	
96	028040246	2	バネザガネ2-4	WASHER, SPRING 2-4	
97	025040236	2	ヒラザガネチユウ4	WASHER, PLAIN M 4	
98	018400836	2	アナボルト4X8	BOLT, SOCKET M4X8	
99	028040246	2	バネザガネ2-4	WASHER, SPRING 2-4	
100	025040236	2	ヒラザガネチユウ4	WASHER, PLAIN M 4	
101	157270101	2	アースコードクミD	GROUND WIRE ASSY, D	
102	150357001	2	コードクランプ13	CORD CLAMP, 13-L	
103	S09142000	26	コードクランプ20L	CORD CLAMP, 20-L	
104	S31760000	7	CKSクランプ26L	CORD CLAMP, 26L	
105	S17024000	5	CKSクランプ20-H	CORD CLAMP, 20-H	
106	S00470000	2	コードホルダー#16	CORD HOLDER, 16N	
107	031451603	2	マルモクネジ4.5X16	WOOD SCREW, ROUND M4.5X16	
109	018402036	1	アナボルト4X20	BOLT, SOCKET M4X20	
110	021400206	1	2シユナツト4	NUT, 2 M4	
111	052400606	2	ナベコバネヒラ4X6	SCREW, PAN (S/P WASHER) M4X6	
112	052401605	1	+ナベコバネヒラ4X16	SCREW, PAN (S/P WASHER) M4X16	
113	S00554000	12	サポート6NS	SUPPORT, 6NS	

From the library of: Diamond Needle Corp

R2 . 電装品関係 / Power supply equipment mechanism / Stromversorgung  
 / Mécanisme de l'équipement en alimentation électrique  
 / Mecanismo del equipo de alimentación de corriente

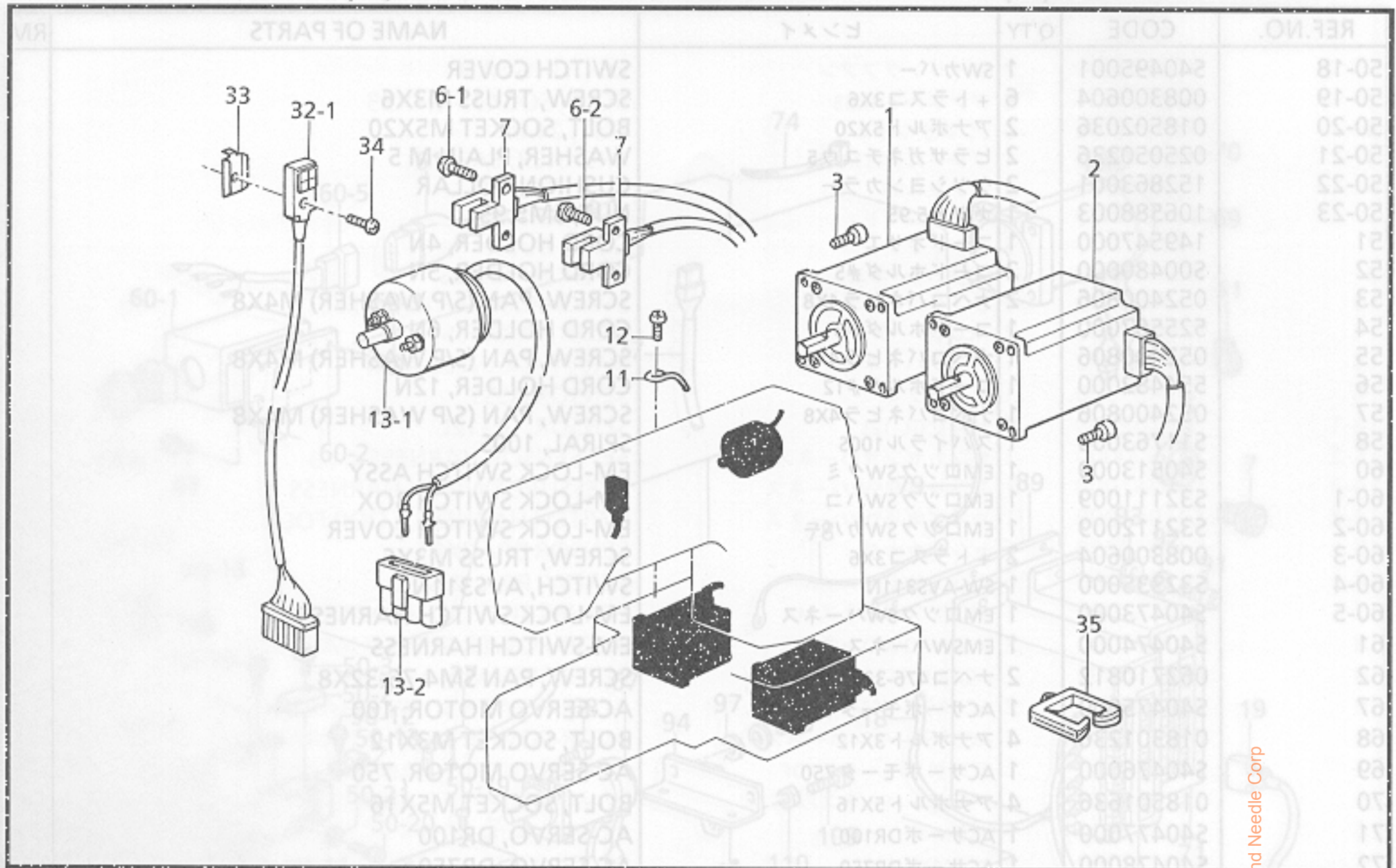

S . 付属装置関係 (オプション部品) / Attachment set (Option parts)  
 / Anbausatz (Sonderzubehör) / Jeu d'accessoires (Pièces en option)  
 / Juego de fijación (Piezas opcionales)

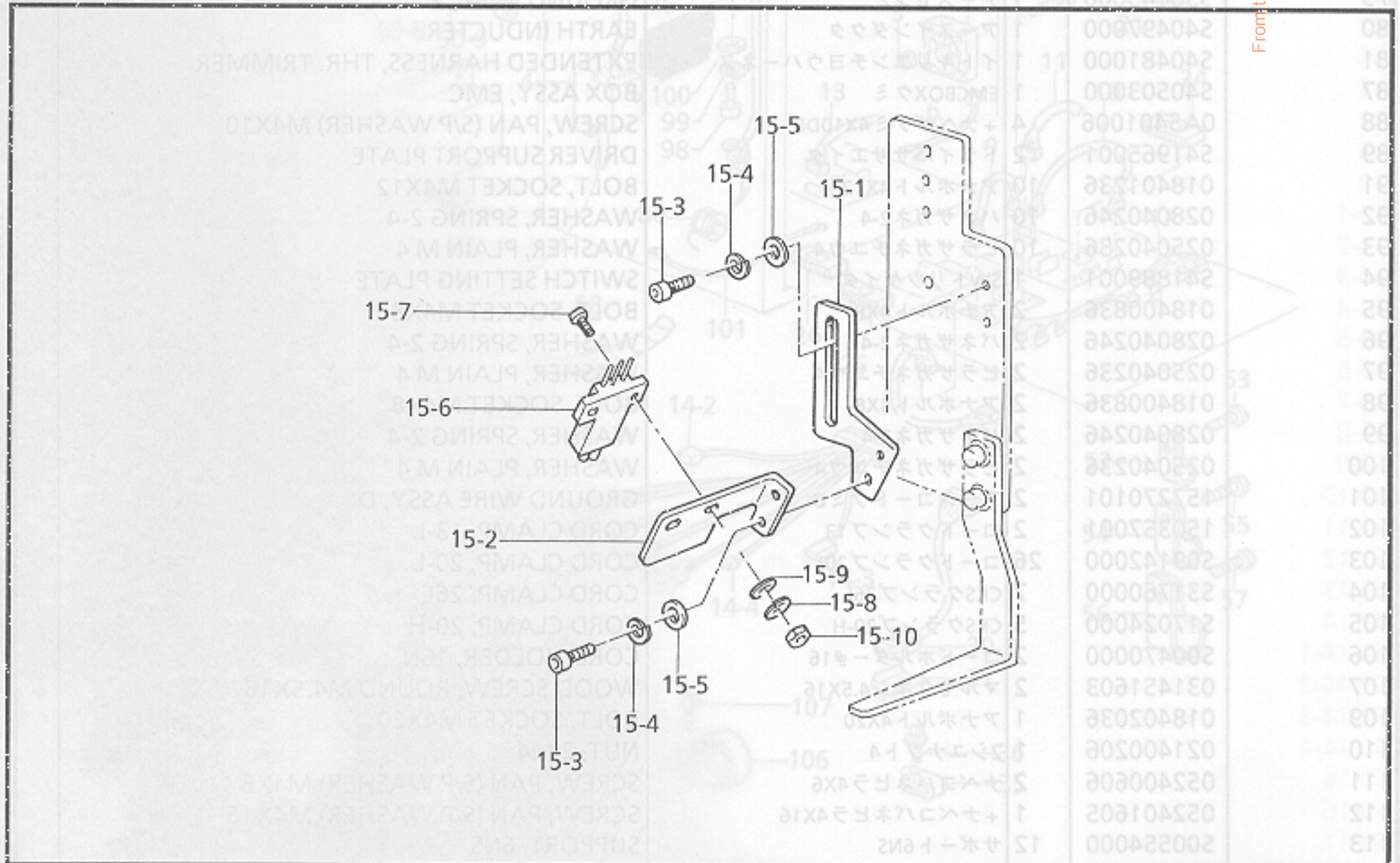

From the library of: Diamond Needle Corp

R2. 電装品関係 / Power supply equipment mechanism / Stromversorgung  
 / Mécanisme de l'équipement en alimentation électrique  
 / Mecanismo del equipo de alimentación de corriente

REF.NO.	CODE	Q'TY	ヒンメイ	NAME OF PARTS	RM
1	S41975000	1	パルスモータXクミ	PULSE MOTOR ASSY, X	
2	S41976000	1	パルスモータYクミ	PULSE MOTOR ASSY, Y	
3	018401222	8	アナボルト4X12	BOLT, SOCKET M4X12	
6	S40431000	1	トウブセンサクミ	HEAD SENSOR ASSY	
6-1	S40432000	1	ゲンテンセンサXハーネス	HOME POSITION SENSOR HARNESS, X	
6-2	S40433000	1	ゲンテンセンサYハーネス	HOME POSITION SENSOR HARNESS, Y	
7	062300412	4	ナベコ3X4	SCREW, PAN M3X4	
11	117150001	2	コードササエカネ	CORD SUPPORT	
12	062670512	2	ナベコ357-40X5	SCREW, PAN SM3.57-40X5	
13-1	S38144000	1	イトキリソレノイドクミ	THREAD TRIMMER SOLENOID ASSY	
13-2	S38146000	1	コネクタ3191-04R	CONNECTOR 3191-04R	
32	S40435000	1	センサクミ	SENSOR ASSY	
32-1	S40436000	1	センサGL-12L	SENSOR, GL-12L	
33	S40437000	1	センサカナグ	SENSOR BRACKET	
34	062300806	1	ナベコ3X8	SCREW, PAN M3X8	
35	S41964000	1	ブツシュ	BUSHING	

From the library of: Diamond Needle Corp

118-705-515

S. 付属装置関係 (オプション部品) / Attachment set (Option parts)  
 / Anbausatz (Sonderzubehör) / Jeu d'accessoires (Pièces en option)  
 / Juego de fijación (Piezas opcionales)

REF.NO.	CODE	Q'TY	ヒンメイ	NAME OF PARTS	RM
15	S41959001	1	<ループセット検知用> ループセンサセットクミ	<FOR LOOP SET DETECTOR> LOOP SET SENSOR ASSY	
15-1	S41628001	1	センサーシジイタ1	SENSOR SUPPORT PLATE, 1	
15-2	S41629001	1	センサーシジイタ2	SENSOR SUPPORT PLATE, 2	
15-3	018400636	4	アナボルト4X6	BOLT, SOCKET M4X6	
15-4	028040246	4	バネザガネ2-4	WASHER, SPRING 2-4	
15-5	025040236	4	ヒラザガネチユウ4	WASHER, PLAIN M 4	
15-6	S31930000	1	フラップセンサ	FLAP SENSOR	
15-7	062301006	2	ナベコ3X10	SCREW, PAN M3X10	
15-8	028030246	2	バネザガネ2-3	WASHER, SPRING 2-3	
15-9	025030236	2	ヒラザガネチユウ3	WASHER, PLAIN M 3	
15-10	021300206	2	2シユナツト3	NUT, 2 M3	

151-705-940

T. プリント基板関係 / Printed circuit board mechanism / Leiterplatten / Circuits imprimés / Tableros de circuitos impresos

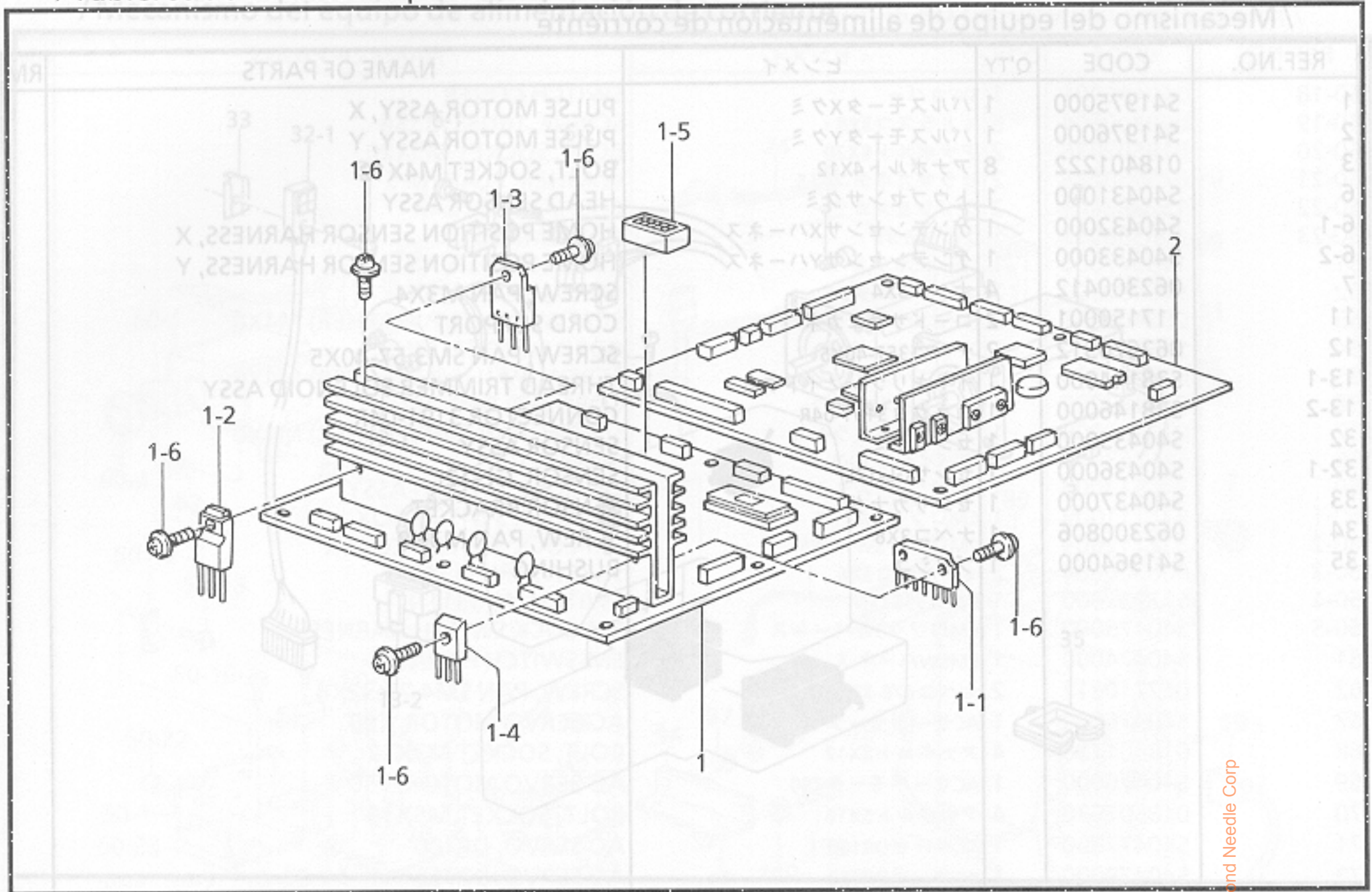

151-705-518

U. 頭部部品関係 / Machine head parts / Teile des maschinenoberteils / Pièces supérieures de la machine / Piezas de la cabeza de la máquina

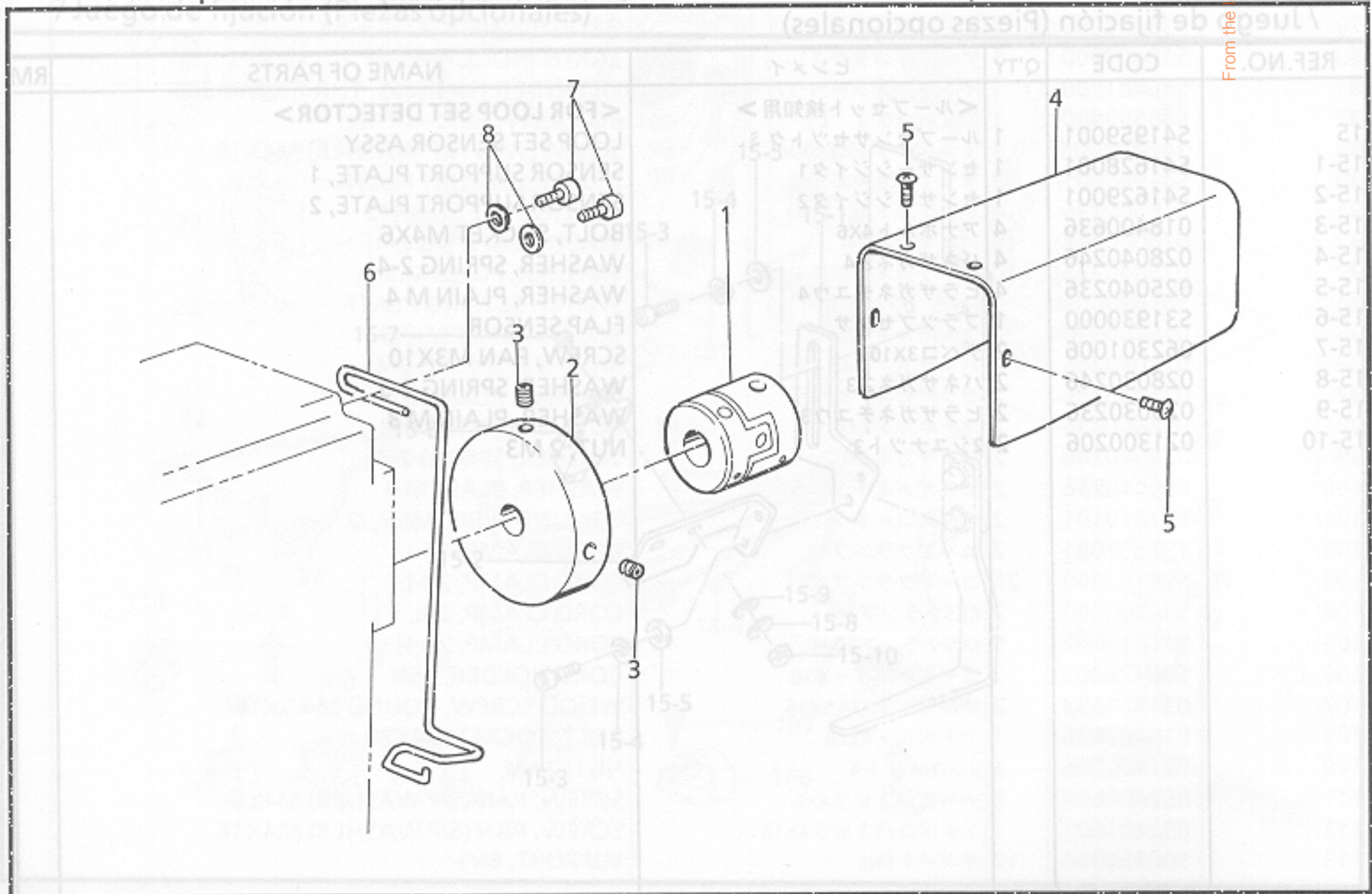

151-705-601

From the library of: Diamond Needle Corp

T. プリント基板関係 / Printed circuit board mechanism / Leiterplatten / Circuits imprimés / Tableros de circuitos impresos

REF.NO.	CODE	Q'TY	ヒンメイ	NAME OF PARTS	RM
1	S38151001	1	<X-Y送り基板用> メインキバンクミ	<For Print Circuit Board for "X-Y Feeding"> MAIN CIRCUIT BOARD ASSY	
1-1	S38154000	4	BIPICSLA4390	BIPICSLA4390	
1-2	S38155000	3	MOSFET2SK1306	MOSFET2SK1306	
1-3	S38164000	6	MOSFET2SK1937	MOSFET2SK1937	
1-4	S33849000	8	FRDアレイ D8LD20U	FRD ARRAY D8LD20U	
1-5	U32744000	1	DIPSWDSS708	DIP SWITCH:DSS708	
1-6	0A4301005	27	+ナベザクミ 3X10DA	SCREW, PAN (S/P WASHER) M3X10	
2	S40489001	1	<メイン基板用> メインキバンクミ	<For Main Print Circuit Board> MAIN PCB ASSY	
2-1	S41893001	4	ワンドキャップ		
2-2	S24194009	2			
2-3	S41887009	1	スタンドフレーム	STAND FRAME	
2-4	021200203	4	ナット 2 M12	NUT, 2 M12	
2-5	152393200	4	ワッシャー	WASHER	
2-6	021160303	4	ナット 1.6	NUT, 1.6	
2-7	133172003	1	ブラケット	BRACKET	
2-8	062501006	1	ナット M3X10	NUT, M3X10	
2-9	S41888009	1	ケーブル	CABLE	
2-10	018082036	4	ボルト M8X20	BOLT, SOCKET M8X20	
2-11	025080236	1	ワッシャー ガネ M8	WASHER, PLAIN M8	
2-12	028080246	1	ワッシャー スプリング 2-8	WASHER, SPRING 2-8	
2-13	S41890009	1	カバー	COVER	
2-14	018080836	6	ボルト M4X8	BOLT, SOCKET M4X8	
2-15	025040236	6	ワッシャー ガネ M4	WASHER, PLAIN M4	
2-16	028040246	6	ワッシャー スプリング 2-4	WASHER, SPRING 2-4	

From the library of: Diamond Needle Corp

151-705-518

U. 頭部部品関係 / Machine head parts / Teile des maschinenoberteils / Pièces supérieures de la machine / Piezas de la cabeza de la máquina

REF.NO.	CODE	Q'TY	ヒンメイ	NAME OF PARTS	RM
1	S41881000	1	カツプリング 19	COUPLING, 19	
2	S41882001	1	ハンドプーリ	HAND PULLEY	
3	012060636	2	アナヒラ 6X6	SET SCREW, SOCKET (FT) M6X6	
4	S41883009	1	ウワジクモーターカバー	UPPER SHAFT MOTOR COVER	
5	008400604	4	+トラスコ 4X6	SCREW, TRUSS M4X6	
6	S41884001	1	ループアンナイ	LOOP GUIDE	
7	018401222	2	アナボルト 4X12	BOLT, SOCKET M4X12	
8	146354001	2	ザガネ	WASHER, PLAIN 5	
8-1	025080236	2	ワッシャー ガネ M8	WASHER, PLAIN M8	
8-2	028080246	2	ワッシャー スプリング 2-8	WASHER, SPRING 2-8	
8-3	501265001	1	レベル調整機	LEVEL ADJUSTER	
8-4	501004000	2	ゴムワッシャー	RUBBER	
8-5	153769001	2	レベル	LEVEL ADJUSTER	
8-6	022120306	2	ナット 3 M12	NUT, 3 M12	
8-7	022120306	2	ナット 3 M12	NUT, 3 M12	
9			<輸出用>	<3-PHASE FOR EXPORT>	
9-1	S41898009	1		TRANSFORMER COVER, THREE PHASE	
9-2	008400604	8		SCREW, TRUSS M4X6	
9-3	S41910009	1		SETTING PLATE, TRANSFORMER	
9-4	018061236	4		BOLT, SOCKET M6X12	
9-5	025060236	4		WASHER, PLAIN M6	
9-6	028060246	4		WASHER, SPRING 2-6	

151-705-601



V. 動力台関係 / Power table / Motorgestell / Mécanisme du plateau de la machine  
/ Mecanismo de la mesa de la máquina

REF.NO.	CODE	Q'TY	ヒンメイ	NAME OF PARTS	RM
			<輸出用>	<FOR EXPORT>	
1	S41885009	1	-----	STAND FRAME ASSY, I	
1-2	S41894001	4	-----	ADJUST SCREW, L	
43	S41899009	2	-----	SUB-STAND, A	
55	S24194009	2	-----	BEAM END CAP	
			<国内用>	<FOR JAPAN ONLY>	
1	S41886009	1	キヤクフレームクミD	-----	
1-2	S41893001	4	チヨウセツネジS	-----	
43	S41900009	2	ホジヨキヤクB	-----	
55	S24194009	2	ハリエンドキャップ	-----	
1-1	S41887009	1	キヤクフレーム	STAND FRAME	
1-3	021200203	4	ナツト2シユ20	NUT, 2 M20	
1-4	152393200	4	キヤスター	CASTER	
1-5	021160303	4	ナツト3シユ16	NUT, 3 M16	
1-6	133172003	1	アブラサシダイ	OIL BRACKET	
1-7	062501006	1	ナベコ5X10	SCREW, PAN M5X10	
4	S41888009	1	テーブル705	TABLE, 705	
6	018082036	4	アナボルト8X20	BOLT, SOCKET M8X20	
7	025080236	4	ヒラザガネチユウ8	WASHER, PLAIN M 8	
8	028080246	4	バネザガネ2-8	WASHER, SPRING 2-8	
9	S41890009	1	ソクメンカバー	SIDE COVER	
10	018400836	6	アナボルト4X8	BOLT, SOCKET M4X8	
11	025040236	6	ヒラザガネチユウ4	WASHER, PLAIN M 4	
12	028040246	6	バネザガネ2-4	WASHER, SPRING 2-4	
13	008400604	5	+トラスコ4X6	SCREW, TRUSS M4X6	
14	S41891001	2	トビラスター	DOOR STAY	
15	S21306001	4	ダンネジ6	STUD SCREW 6	
16	S41892009	1	ハイメンカバー	REAR COVER	
17	008400604	6	+トラスコ4X6	SCREW, TRUSS M4X6	
24	S15158009	1	コモノケース	ACCESSORY CASE	
25	S02740000	1	フェルト	FELT	
26	S02739000	1	ゴムジシャクテープ	RUBBER MAGNET TAPE	
27	039411215	2	1トラスタツピン4X12	TAPPING SCREW, TRUSS 1 M4X12	
30	S41895001	1	クサリクミ	CHAIN ASSY	
31	S41909000	1	フック	HOOK	
39	S41896000	1	アースイタL	GROUND PLATE, L	
40	S41897000	1	アースイタR	GROUND PLATE, R	
44	018081636	4	アナボルト8X16	BOLT, SOCKET M8X16	
45	025080236	4	ヒラザガネチユウ8	WASHER, PLAIN M 8	
46	028080246	4	バネザガネ2-8	WASHER, SPRING 2-8	
48	S01265001	2	レベルザクミ	LEVEL ADJUSTER ASSY	
48-1	S01004000	2	キヤクゴムウシロ	RUBBER	
48-2	153769001	2	レベルザ	LEVEL ADJUSTER	
48-3	022120306	2	ナツト3シユ12	NUT, 3 M12	
49	022120306	2	ナツト3シユ12	NUT, 3 M12	
			<輸出用>	<3-PHASE FOR EXPORT>	
41	S41898009	1	-----	TRANSFORMER COVER, THREE PHASE	
42	008400604	8	-----	SCREW, TRUSS M4X6	
50	S41910009	1	-----	SETTING PLATE, TRANSFORMER	
51	018061236	4	-----	BOLT, SOCKET M6X12	
52	025060236	4	-----	WASHER, PLAIN M 6	
53	028060246	4	-----	WASHER, SPRING 2-6	

From the library of: Diamond Needle Corp



W. 付属装置関係 (オプション部品) / Attachment set (Option parts)  
 / Anbausatz (Sonderzubehör) / Jeu d'accessoires (Pièces en option)  
 / Juego de fijación (Piezas opcionales)

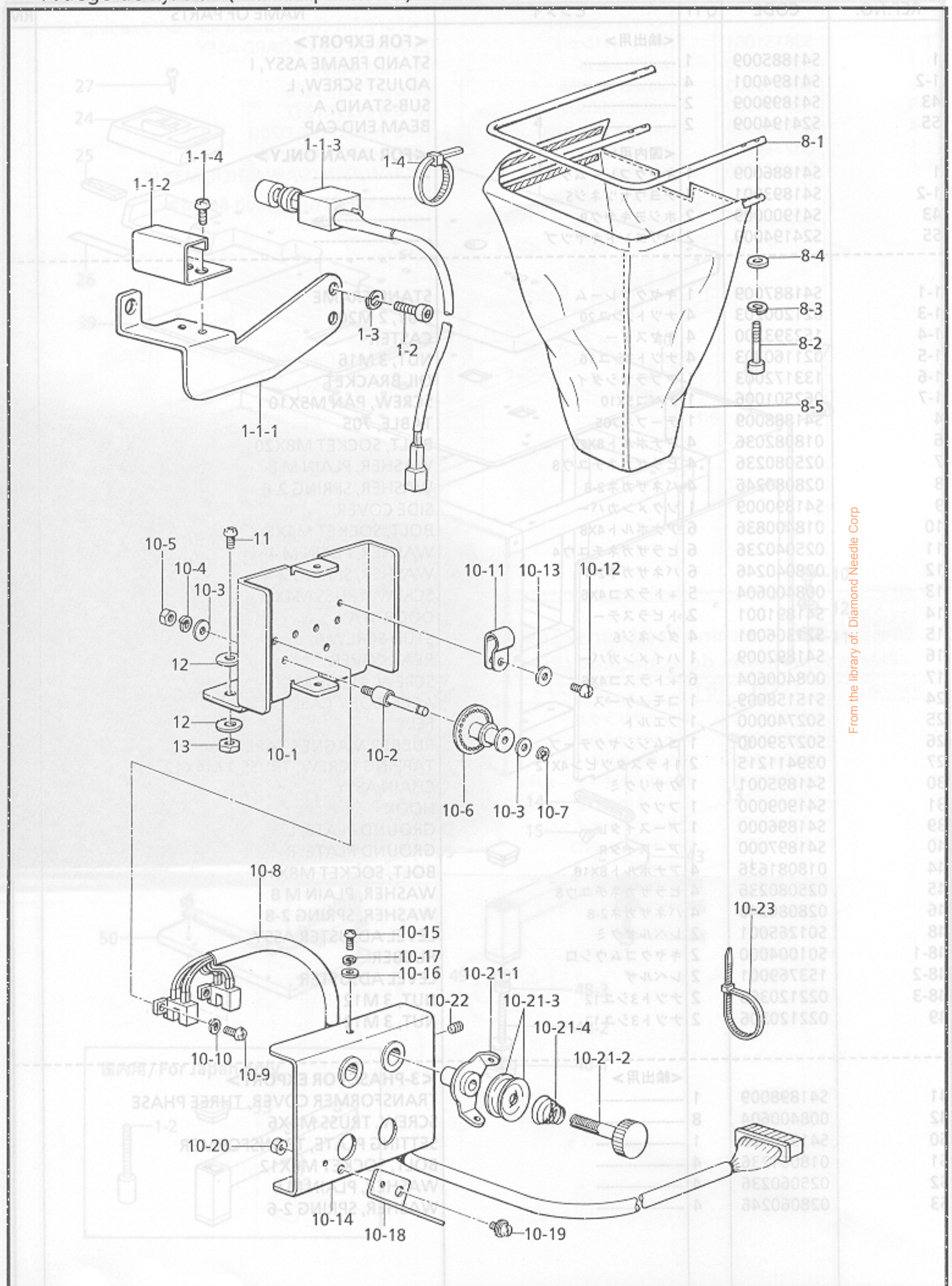

From the library of: Diamond Needle Corp

W. 付属装置関係 (オプション部品) / Attachment set (Option parts)  
 / Anbausatz (Sonderzubehör) / Jeu d'accessoires (Pièces en option)  
 / Juego de fijación (Piezas opcionales)

REF.NO.	CODE	Q'TY	ヒンメイ	NAME OF PARTS	RM
1	S41639001	1	<手動ループ折込みスイッチ> ハンドセットスイッチソウクミ	<Hand operation SW for folding the loop> HAND SET SWITCH UNIT	
1-1	S41640001	1	ハンドセットスイッチクミ	HAND SET SWITCH ASSY	
1-1-1	S41638001	1	ハンドスイッチダイ	HAND SWITCH BASE	
1-1-2	S14972001	1	ハンドSWカバー	HAND SWITCH COVER	
1-1-3	S40496000	1	ハンドSWクミ	HAND SWITCH ASSY	
1-1-4	008300604	2	+トラスコ3X6	SCREW, TRUSS M3X6	
1-2	018400636	2	アナボルト4X6	BOLT, SOCKET M4X6	
1-3	028040246	2	バネザガネ2-4	WASHER, SPRING 2-4	
1-4	S04557000	3	バンタイPLTIM	BAND, PLTIM	
8	S41906001	1	<切り屑処理装置> キリクスシヨリソウクミ	<Clipping Disposal Funnel Assembly> CLIPPING DISPOSAL FUNNEL ASSY	
8-1	S41907001	2	ミゴロウケバー	CLOTH SUPPORT BAR	
8-2	018065022	4	アナボルト6X50	BOLT, SOCKET M6X50	
8-3	028060242	4	バネザガネ2-6	WASHER, SPRING 2-6	
8-4	118735002	4	ザガネ	WASHER	
8-5	S41908001	1	キリクスシヨリフクロ	CLIPPING DISPOSAL FUNNEL	
10	S40520009	1	<上糸切れ検知装置> ウワイトギレケンチクミ	<Upper Tr. Breakage Detector Assembly> UPPER THREAD BREAKAGE DETECTOR ASSY	
10-1	S09400009	1	トリツケダイ	SETTING BRACKET	
10-2	S09401001	2	シテンジク	FULCRUM SHAFT	
10-3	025030233	4	ヒラザガネチユウ3	WASHER, PLAIN M 3	
10-4	028030243	2	バネザガネ2-3	WASHER, SPRING 2-3	
10-5	021300103	2	ナツト1シユ3	NUT, 1 M3	
10-6	S09402101	2	プーリー	PULLEY	
10-7	048020342	2	トメワE2	RETAINING RING, E2	
10-8	S40519000	1	イトキレセンサークミ	THREAD BREAKAGE SESOR ASSY	
10-9	062300616	4	ナベコM3X6	SCREW, PAN M3X6	
10-10	028030243	4	バネザガネ2-3	WASHER, SPRING 2-3	
10-11	S00480000	1	コードホルダ#5	CORD HOLDER, 5N	
10-12	062400616	1	ナベコM4X6	SCREW, PAN M4X6	
10-13	025040233	1	ヒラザガネチユウ4	WASHER, PLAIN M 4	
10-14	S09403009	1	カバー	COVER	
10-15	062300616	2	ナベコM3X6	SCREW, PAN M3X6	
10-16	025030233	2	ヒラザガネチユウ3	WASHER, PLAIN M 3	
10-17	028030243	2	バネザガネ2-3	WASHER, SPRING 2-3	
10-18	S03566001	1	メンイタイトカケ	FACE PLATE THREAD HOOK	
10-19	052400806	1	ナベコバネヒラ4X8	SCREW, PAN (S/P WASHER) M4X8	
10-20	021400202	1	2シユナツト4	NUT, 2 M4	
10-21	183377001	2	プレテンションクミA	PRE-TENSION ASSY, A	
10-21-1	S02611001	2	イトアンナイ	THREAD GUIDE	
10-21-2	S02612001	2	イトアンナイチヨウシボウ	PRE-TENSION STUD	
10-21-3	144504001	2	イトアンナイサラ	THREAD GUIDE DISC	
10-21-4	154560001	2	プレテンションバネA	SPRING, PRE-TENSION (A)	
10-22	014500522	2	アナトメネジ5クボミ	SET SCREW, SOCKET (CP) M5	
10-23	S04557000	1	バンタイPLTIM	BAND, PLTIM	
11	062761212	2	ナベコ595-28X12	SCREW, PAN SM5.95-28X12	
12	025060232	4	ヒラザガネチユウ6	WASHER, PLAIN M 6	
13	100022005	2	ナツト5.95	NUT, SM5.95	

From the library of: Diamond Needle Corp

Z. 付属品関係 / Accessories / Zubehör / Accessoires / Accesorios

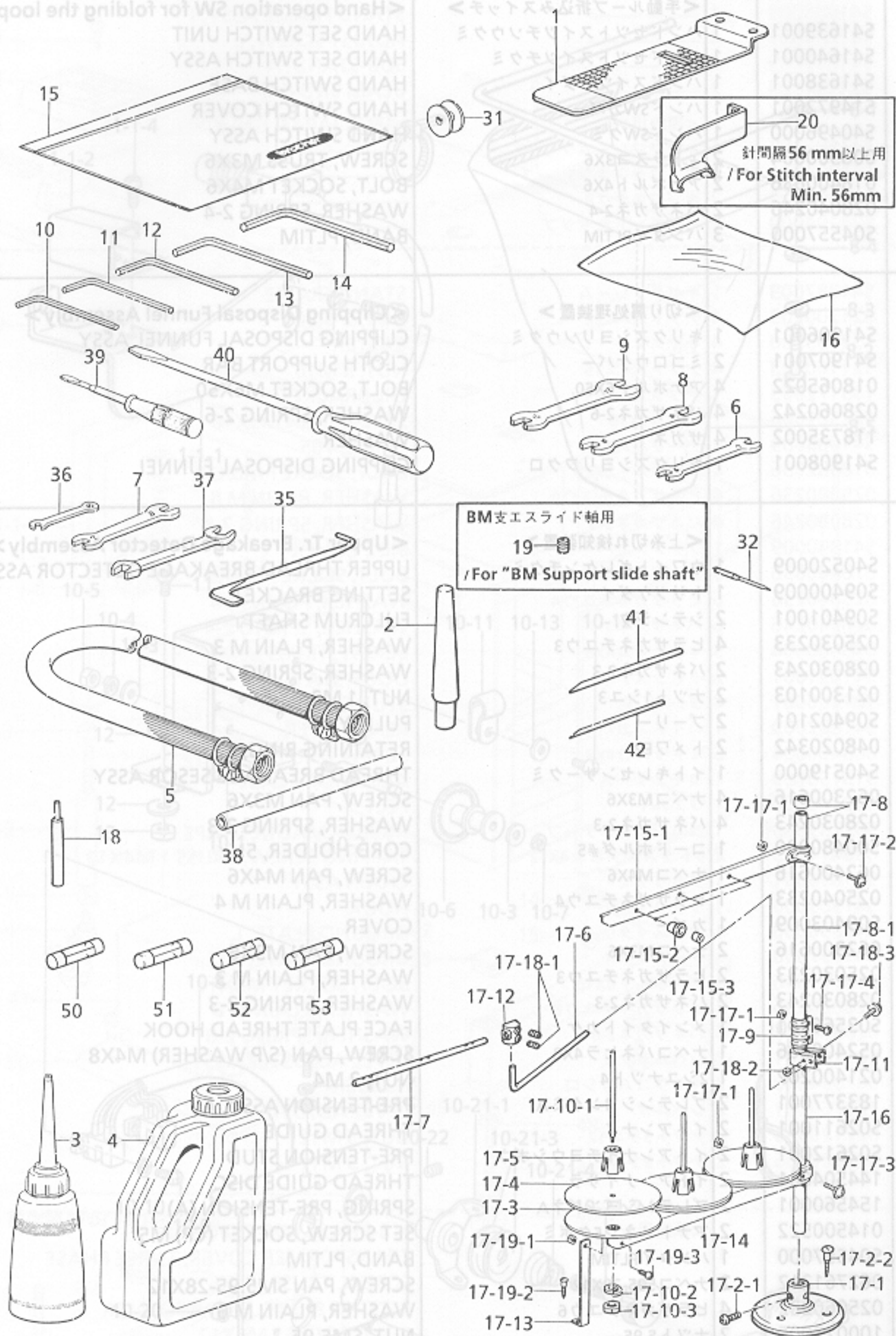

◎ 付属品の明細は変更することがあります。  
 ◎ The details of included accessories are subject to change.  
 ◎ Änderungen in der Aufstellung der Mitgelieferten  
 Zubehöre sind vorbehalten.

◎ Les détails des accessoires inclus sont sujets à des changements.  
 ◎ Los detalles de accesorios incluidos pueden variar.

From the library of: Diamond Needle Corp



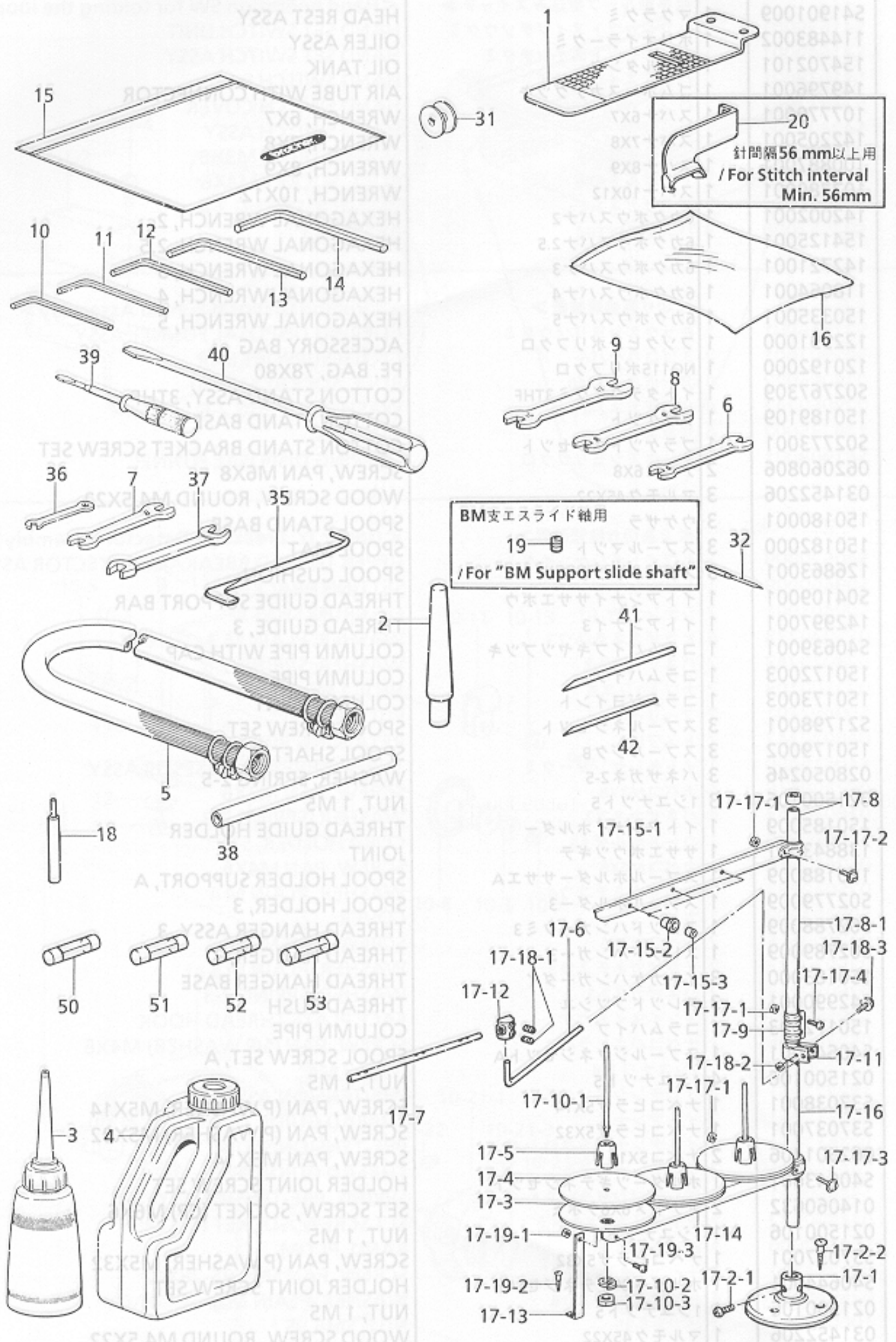

REF.NO.	CODE	Q'TY	ヒンメイ	NAME OF PARTS	RM
18	S41803001	1	オクリイタ	FEED PLATE	
21	S41901009	1	マクラクミ	HEAD REST ASSY	
32	114483002	1	ポリオイラークミ	OILER ASSY	
45	154702101	1	オイルタンク	OIL TANK	
56	149796001	1	ゴムホースカナグツキ	AIR TUBE WITH CONNECTOR	
67	107779001	1	スパナ6X7	WRENCH, 6X7	
78	142205001	1	スパナ7X8	WRENCH, 7X8	
89	100887001	1	スパナ8X9	WRENCH, 8X9	
90	107780001	1	スパナ10X12	WRENCH, 10X12	
10	142002001	1	6カクボウスパナ2	HEXAGONAL WRENCH, 2	
11	154125001	1	6カクボウスパナ2.5	HEXAGONAL WRENCH, 2.5	
12	142721001	1	6カクボウスパナ3	HEXAGONAL WRENCH, 3	
13	118064001	1	6カクボウスパナ4	HEXAGONAL WRENCH, 4	
14	150335001	1	6カクボウスパナ5	HEXAGONAL WRENCH, 5	
15	122991000	1	フソクヒンポリフクロ	ACCESSORY BAG	
16	120192000	1	NO115ポリフクロ	PE. BAG, 78X80	
17	S02767309	1	イトタテダイクミ3THF	COTTON STAND ASSY, 3THF	
17-1	150189109	1	ブラケット	COTTON STAND BASE	
17-2	S02773001	1	ブラケットネジセット	COTTON STAND BRACKET SCREW SET	
17-2-1	062060806	2	ナベコ6X8	SCREW, PAN M6X8	
17-2-2	031452206	3	マルモク45X22	WOOD SCREW, ROUND M4.5X22	
17-3	150180001	3	ウケザラ	SPOOL STAND BASE	
17-4	150182000	3	スプールのマット	SPOOL MAT	
17-5	126863001	3	スプールのクッション	SPOOL CUSHION	
17-6	S04109001	1	イトアンナイササエボウ	THREAD GUIDE SUPPORT BAR	
17-7	142997001	1	イトアンナイ3	THREAD GUIDE, 3	
17-8	S40639001	1	コラムパイプキャップツキ	COLUMN PIPE WITH CAP	
17-8-1	150172003	1	コラムパイプ	COLUMN PIPE	
17-9	150173003	1	コラムジョイント	COLUMN JOINT	
17-10	S21798001	3	スプールのネジセット	SPOOL SCREW SET	
17-10-1	150179002	3	スプールのジク	SPOOL SHAFT, B	
17-10-2	028050246	3	バネザガネ2-5	WASHER, SPRING 2-5	
17-10-3	021500106	3	1シユナツト5	NUT, 1 M5	
17-11	150185009	1	イトアンナイホルダー	THREAD GUIDE HOLDER	
17-12	138843001	1	ササエボウツギテ	JOINT	
17-13	150188009	1	スプールのホルダーササエA	SPOOL HOLDER SUPPORT, A	
17-14	S02779009	1	スプールのホルダー3	SPOOL HOLDER, 3	
17-15	S02788009	1	スレツドハンガークミ3	THREAD HANGER ASSY, 3	
17-15-1	S02789009	1	スレツドハンガー3	THREAD HANGER, 3	
17-15-2	150183000	3	イトカケハンガーダイ	THREAD HANGER BASE	
17-15-3	142990001	3	スレツドブツシュ	THREAD BUSH	
17-16	150172003	1	コラムパイプ	COLUMN PIPE	
17-17	S40641001	1	スプールのジクネジセットA	SPOOL SCREW SET, A	
17-17-1	021500106	4	1シユナツト5	NUT, 1 M5	
17-17-2	S37038001	1	ナベコヒラザ5X14	SCREW, PAN (P WASHER) M5X14	
17-17-3	S37037001	1	ナベコヒラザ5X32	SCREW, PAN (P WASHER) M5X32	
17-17-4	062501406	2	ナベコ5X14	SCREW, PAN M5X14	
17-18	S40643001	1	ホルダーツギテネジセット	HOLDER JOINT SCREW SET	
17-18-1	014060632	2	アナトメ6X6クボミ	SET SCREW, SOCKET (CP) M6X6	
17-18-2	021500106	1	1シユナツト5	NUT, 1 M5	
17-18-3	S37037001	1	ナベコヒラザ5X32	SCREW, PAN (P WASHER) M5X32	
17-19	S40644001	1	ホルダーツギテネジセット	HOLDER JOINT SCREW SET	
17-19-1	021500106	1	1シユナツト5	NUT, 1 M5	
17-19-2	031452206	1	マルモク45X22	WOOD SCREW, ROUND M4.5X22	
17-19-3	062501006	1	ナベコ5X10	SCREW, PAN M5X10	

From the library of: Diamond Needle Corp



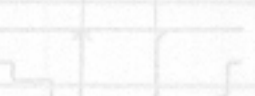

◎ 付属品の明細は変更することがあります。  
 ◎ The details of included accessories are subject to change.  
 ◎ Änderungen in der Aufstellung der Mitgelieferten  
 Zubehöre sind vorbehalten.

◎ Les détails des accessoires inclus sont sujets à des changements.  
 ◎ Los detalles de accesorios incluidos pueden variar.

REF.NO.	CODE	Q'TY	ヒンメイ	NAME OF PARTS	RM
18	S41903001	1	ハリアナジグ	NEEDLE HOLE JIG	
31	S15665001	4	ボビンLA	BOBBIN, LA	
32	S37928419	1	ミシンハリDP17NY19クミ	NEEDLE DP17NY (#19) ASSY	
35	S08170001	1	Zガタネジマワシ	SCREW DRIVER, Z-STEEL	
36	S23926001	1	スパナ5	WRENCH, 5	
37	S14696001	1	スパナ11X13	WRENCH, 11X13	
38	154760001	1	ボウスパナパイプ	PIPE WRENCH	
39	118837001	1	ネジマワシ3.4X70	SCREW DRIVER, 3.4X70	
40	101572101	1	ネジマワシ5.5X190	SCREW DRIVER, 5.5X190	
41	S41623001	2	ホークジク1.8L	FORK SHAFT, 1.8L	
42	S41624001	2	ホークジク1.8S	FORK SHAFT, 1.8S	
50	215769001	1	カンヒューズ3A	FUSE, 3A	
51	152566000	3	ヒューズC	FUSE C, 2A	
52	153242000	1	ヒューズ6A	FUSE, 6A	
53	157219000	2	カンヒューズ5A-D	FUSE, 5A	
			<針間隔56 mm以上用>	<For Stitch interval Min. 56mm>	
20	S41605001	1	ウエガイドイタB	UPPER GUIDE PLATE, B	
-----					
19	012400436	1	<BM支エスライド軸用> アナヒラ4X4	<For "BM Support slide shaft"> SET SCREW, SOCKET (FT) M4X4	
51	S41803051				
52	S41803052				
53	S41803053				
54	S41803054				
55	S41803055				
56	S41803056				
57	S41803057				
58	S41803058				
59	S41803059				
60	S41803060				
61	S41803061				
62	S41803062				
63	S41803063				
64	S41803064				
65	S41803065				
66	S41803066				
67	S41803067				
68	S41803068				
69	S41803069				
70	S41803070				

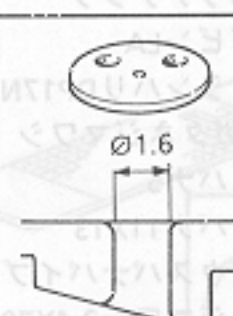
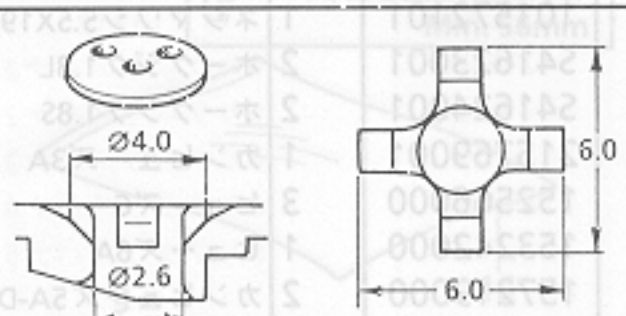
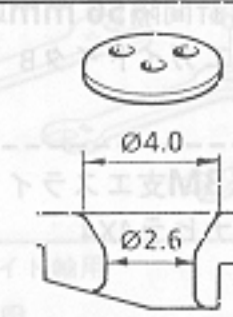
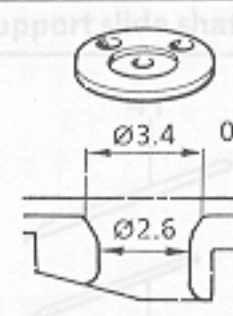
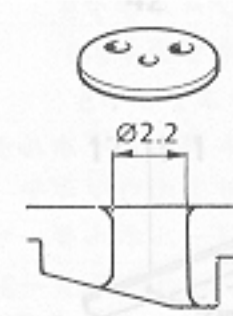
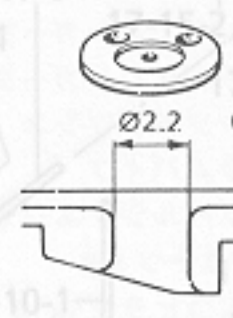
From the library of: Diamond Needle Corp

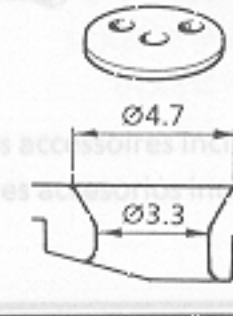
REF.NO.	CODE	品名	NAME OF PARTS	
1	S10211001	針穴板A	NEEDLE HOLE PLATE, A	
2	S29997001	針穴板D	NEEDLE HOLE PLATE, D	
3	S10212101	針穴板E	NEEDLE HOLE PLATE, E	
4	S30925001	針穴板ED	NEEDLE HOLE PLATE, ED	
5	S10213001	針穴板F	NEEDLE HOLE PLATE, F	
6	S30926001	針穴板FD	NEEDLE HOLE PLATE, FD	
7	S30450001	針穴板H	NEEDLE HOLE PLATE, H	
8	S25127001	針穴板L	NEEDLE HOLE PLATE, L	

From the library of: Diamond Needle Corp



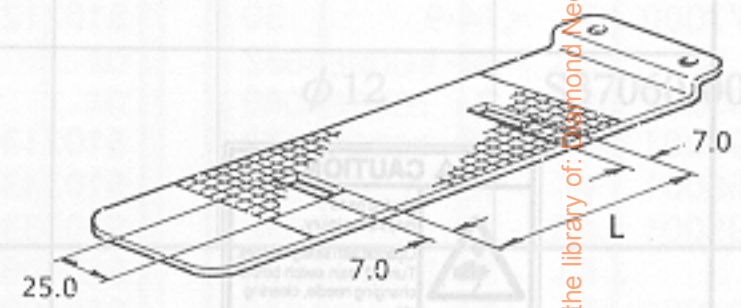



REF.NO.	CODE	品名 / NAME OF PARTS	L (mm)
10	S41803001	送り板 / FEED PLATE	0
41	S41803041	↑	41
42	S41803042	↑	42
43	S41803043	↑	43
44	S41803044	↑	44
45	S41803045	↑	45
46	S41803046	↑	46
47	S41803047	↑	47
48	S41803048	↑	48
49	S41803049	↑	49
50	S41803050	↑	50
51	S41803051	↑	51
52	S41803052	↑	52
53	S41803053	↑	53
54	S41803054	↑	54
55	S41803055	↑	55
56	S41803056	↑	56
57	S41803057	↑	57
58	S41803058	↑	58
59	S41803059	↑	59
60	S41803060	↑	60
61	S41803061	↑	61
62	S41803062	↑	62
63	S41803063	↑	63
64	S41803064	↑	64
65	S41803065	↑	65
66	S41803066	↑	66
67	S41803067	↑	67
68	S41803068	↑	68
69	S41803069	↑	69
70	S41803070	↑	70



From the library of: Diamond Needle Corp





Wa1. 警告ラベル / Warning labels / Warnschilder / Etiquettes d'avertissement / Etiquetas de advertencia

REF. NO.	CODE	品名 / Name of parts	Size(mm)	Code
1	S10211001	電撃ラベル・和 	40 × 64	S38353-001
2	S30907001	Label, elec. shock 4 lang. 	35 × 118	S38352-001
3	S10212101	操作注意ラベル・BAS和 	40 × 64	S38357-001
			52 × 84	S38357-002
4	S30925001	Label, operation(BAS) Eng. 	40 × 64	S38571-001
			52 × 84	S38571-002
6	S30926001	高温ラベル Label, high temp. 	72 × 59	S38351-001
7	S3045001	はさみ込み注意ラベル Label, pinch 	40 × 84	S38355-001

From the library of: Diamond Needles Corp.

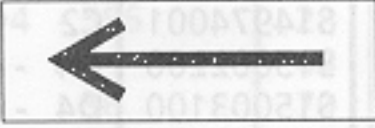
Wa2. 警告ラベル / Warning labels / Warnschilder / Etiquettes d'avertissement  
/ Etiquetas de advertencia

	品名 / Name of parts	Size(mm)	Code
	ワーニングマーク Mark, injury	L=16 R=0.8	S36924-001
	矢印マーク Mark, arrow	10×30	S37058-001
	PEマーク Mark, PE	7.5×12.5	S37059-001
	アースマーク Mark, grounding	φ12	S37060-001

From the library of: Diamond Needle Corp

索引 / INDEX / VERZEICHIS  
/ INDEX / INDICE

CODE	REF.NO.	Page	CODE	REF.NO.	Page	CODE	REF.NO.	Page
S00470000	R1 - 106	58	S09027001	F - 14	32	S14874000	D2 - 135	16
S00480000	W - 10-11	66	S09043000	G1 - 31	36	S14919000	D4 - 428	24
	R1 - 52	58	S09132001	D1 - 107	14	S14920000	D4 - 433	24
S00505001	K - 2-31	42		D1 - 115	14	S14924001	D4 - 423	24
S00554000	R1 - 113	58	S09142000	R1 - 103	58	S14946101	D4 - 458	24
S00705001	F - 75	34	S09197000	A2 - 88	6	S14947101	D4 - 466	26
	L - 47	46	S09212001	C1 - 5-1	10	S14948101	D4 - 470	26
S01004000	V - 48-1	64	S09231000	Q - 1-1	52	S14949101	D4 - 462	24
S01265001	V - 48	64	S09400009	W - 10-1	66	S14950001	D4 - 463	26
S02354001	L - 23	44	S09401001	W - 10-2	66	S14958101	D4 - 450	24
S02427201	E - 14	30	S09402101	W - 10-6	66	S14972001	W - 1-1-2	66
S02428001	E - 14-1	30	S09403009	W - 10-14	66	S14974001	C2 - 7-10	12
S02429101	E - 14-2	30	S10162201	G1 - 15	36	S15002200	D4 - 491	26
	F - 42-2	32	S10195001	L - 30	44	S15003100	D4 - 491-1	26
S02556001	F - 37	32	S10202101	L - 41	44	S15056001	P - 10	50
S02611001	W - 10-21-1	66	S10205001	F - 73	34	S15158009	V - 24	64
S02612001	W - 10-21-2	66		L - 45	44	S15662991	F - 101	34
S02652001	L - 6	44	S10208001	F - 74	34	S15663991	E - 101	30
S02654001	L - 7-1	44		L - 46	44	S15665001	E - 103	30
S02739000	V - 26	64	S10208002	F - 74	34		F - 103	34
S02740000	V - 25	64		L - 46	44		Z - 31	70
S02767309	Z - 17	68	S10208003	F - 74	34	S15667001	E - 102-3	30
S02773001	Z - 17-2	68		L - 46	46		F - 102-3	34
S02779009	Z - 17-14	68	S10209101	F - 76	34	S15700009	D4 - 440	24
S02788009	Z - 17-15	68		L - 48	46	S16074101	E - 102	30
S02789009	Z - 17-15-1	68	S10211001	Ga1 - 1	71		F - 102	34
S02877000	E - 14-9	30	S10212101	F - 80	34	S16122000	D1 - 22	14
	F - 42-11	32		L - 53	46		D1 - 31	14
S03303001	J - 2	40		Ga1 - 3	71	S16422001	D2 - 229	18
S03490001	F - 36	32	S10213001	Ga1 - 5	71	S16431001	C2 - 1-1-	12
S03566001	W - 10-18	66	S10243000	R1 - 50-12	56		C2 - 1-2-	12
S03695001	A2 - 21	4	S10333000	R1 - 6	56	S16492101	E - 102-2	30
	R1 - 50-17	56	S10408000	P - 9	50		F - 102-2	34
S03704001	E - 13	30	S10409002	P - 8	50	S16566000	R1 - 1	56
S04109001	Z - 17-6	68	S10478000	G1 - 10	36	S16669000	K - 2-27	42
S04557000	Q - 27	52	S11170001	L - 34	44	S17024000	R1 - 105	58
	W - 1-4	66	S11440004	M - 8	48	S17028000	Q - 1-4	52
	W - 10-23	66	S11733000	R1 - 78	58	S18093100	A2 - 78-4	6
	R1 - 74	58	S11763000	P - 20	50		G1 - 25	36
S04891000	Q - 5	52		Q - 28	52	S18387004	A2 - 25	4
S04897000	Q - 20-6	54		R1 - 58	58	S18387007	C2 - 12	12
	Q - 21-7	52	S11816000	R1 - 35	56	S18974101	E - 102	30
S05356000	D3 - 351	20	S12004000	D2 - 192	16		F - 102	34
S06857000	Q - 6	52	S12054000	D2 - 196	16	S19543001	C2 - 25	12
S06858000	Q - 6-1	52	S12134001	D1 - 112	14	S19557000	H - 19	38
S06859000	Q - 6-2	52	S12150000	D1 - 118-4	14		Q - 71	52
S07071001	J - 3	40		D2 - 153-2	16		Q - 78	52
S07129001	D4 - 425	24		D2 - 157-2	16		C2 - 16	12
S07333001	G1 - 2	36		D2 - 225-2	18	S19959101	D4 - 489	26
	G2 - 16	38		D3 - 320-2	20	S20871001	R1 - 50-2	56
S07370102	R1 - 50-15	56		D3 - 348-2	20	S21103000	K - 2-26	42
S07424001	H - 3	38		D4 - 494-2	26	S21306001	V - 15	64
S07456000	G1 - 3	36	S13330001	D2 - 228	18	S21527001	G1 - 14	36
S07488001	J - 1-10	40	S13385001	D4 - 523	26	S21715001	D2 - 256	18
S07512001	L - 25-2	44	S13744001	F - 35-1	32	S21716001	C2 - 7-13	12
S07553001	H - 1	38	S14085001	Q - 75	52	S21798001	Z - 17-10	68
S08125000	C2 - 13	12		A2 - 89	6	S23653001	D2 - 194	16
S08170001	Z - 35	70	S14085008	Q - 70	52	S23696101	D4 - 422	24
S08176000	Q - 56	52	S14159000	Q - 20-4	54	S23697001	D4 - 429	24
	Q - 57	52		Q - 21-5	52	S23698001	D4 - 430	24
S08605101	J - 1-20	40	S14473000	A2 - 23	4	S23699101	D4 - 431	24
S08606001	J - 1-21	40	S14696001	Z - 37	70	S23701101	D4 - 454	24
S08610101	J - 1-23	40	S14874000	D1 - 127	14	S23702201	D4 - 456	24

From the Library of: Diamond Needle Corp

CODE	REF.NO.	Page
S23703101	D4 - 456-1	24
S23709001	D4 - 517	26
S23710001	D4 - 519	26
S23711001	D4 - 521	26
S23713001	D4 - 529	28
S23714001	D4 - 532	28
S23715001	D4 - 533	28
S23717001	D4 - 536	28
S23718001	D4 - 539	28
S23741000	D4 - 491-2	26
S23747001	Q - 30	52
S23794001	D4 - 556	28
S23836001	L - 7	44
S23926001	Z - 36	70
S24089001	D1 - 12	14
S24175000	D4 - 494-1	26
S24194009	V - 55	64
	V - 55	64
S24250001	D1 - 38	14
S24949000	C2 - 34	12
S25127001	Ga1 - 8	71
S27852001	D4 - 510	26
S27853001	D4 - 526	26
S28090001	C1 - 6-8	10
S28741000	H - 18	38
S29997001	Ga1 - 2	71
S30033001	L - 21-3	44
S30450001	Ga1 - 7	71
S30925001	Ga1 - 4	71
S30926001	Ga1 - 6	71
S31169000	Q - 1-2	52
S31170000	Q - 11	52
S31258001	D2 - 149	16
S31704000	A2 - 51	4
S31706000	F - 67	34
	Q - 59	52
	Q - 61	52
	Q - 65	52
S31760000	R1 - 104	58
S31764000	Q - 8	52
S31930000	S - 15-6	60
S31960009	K - 2-28	42
S31961009	K - 2-1	42
S32111009	R1 - 60-1	58
S32112009	R1 - 60-2	58
S32294001	R1 - 2	56
	R1 - 50-5	56
S32335000	R1 - 60-4	58
S33849000	T - 1-4	62
S33870001	Q - 77	52
S33896001	D3 - 315	20
S34844001	A1 - 85-1-1	2
S34845001	A1 - 85-1-2	2
S34982000	G1 - 36	36
	G2 - 4	38
S34983000	G1 - 34	36
S34986000	G1 - 11	36
	G1 - 35	36
S35001000	G2 - 12	38
S35020001	D4 - 535	28
S35032101	K - 2-6	42
S36070001	A1 - 85-1-4	2
S36071001	A1 - 85-1-3	2

CODE	REF.NO.	Page
S36691001	A1 - 85-1	2
S36924001	Wa2	74
S37037001	Z - 17-17-3	68
	Z - 17-18-3	68
S37038001	Z - 17-17-2	68
S37058001	Wa2	74
S37059001	Wa2	74
S37060001	Wa2	74
S37454000	D2 - 158	16
	D4 - 494-3	26
S37915009	A1 - 14	2
S37920009	A1 - 26	2
S37927000	B - 17	8
S37928019	B - 29	8
S37928021	B - 29	8
S37928419	Z - 32	70
S37932001	C1 - 1-5	10
	C1 - 6-2	10
S37933001	C1 - 1-6	10
	C1 - 6-3	10
S37934001	C1 - 4	10
S37936001	C1 - 6-1	10
S37937001	C1 - 19	10
S37939001	C1 - 22	10
S37940001	B - 28	8
	C1 - 25	10
S37941001	C1 - 20	10
S37942000	C1 - 27	10
S37943000	C1 - 28	10
S37944000	C1 - 29	10
S37946001	C1 - 34	10
S37947001	C1 - 36	10
S37978051	E - 5	30
S37981051	E - 9	30
S37983001	G1 - 6	36
S37984000	G1 - 17	36
	G1 - 45	36
S37985000	G1 - 23	36
S37986000	G1 - 24	36
S37987001	G1 - 28	36
S37988000	G1 - 29	36
S38001001	L - 1	44
S38002001	L - 3	44
S38003001	L - 8	44
S38004002	L - 10	44
S38004003	L - 10	44
S38004004	L - 10	44
S38005001	L - 15	44
S38006001	L - 21	44
S38007001	L - 21-1	44
S38008001	L - 25	44
S38009001	L - 25-1	44
S38010001	L - 29	44
S38016001	L - 44	44
S38144000	R2 - 13-1	60
S38145000	R1 - 79	58
S38146000	R2 - 13-2	60
S38151001	T - 1	62
S38154000	T - 1-1	62
S38155000	T - 1-2	62
S38164000	T - 1-3	62
S38274001	J - 1-8	40
S38351001	Wa1	73

CODE	REF.NO.	Page
S38352001	Wa1	73
S38353001	Wa1	73
S38355001	Wa1	73
S38357001	Wa1	73
S38357002	Wa1	73
S38571001	Wa1	73
S38571002	Wa1	73
S38819000	R1 - 4	56
S38820000	R1 - 5	56
S39113000	Q - 9	52
S39115000	Q - 20-2	54
	Q - 21-3	52
S39116000	Q - 20-3	54
	Q - 21-4	52
S39847001	K - 2-21	42
S39902001	K - 2-2	42
S39903001	K - 2-7	42
S39908000	K - 2-21-1	42
S40431000	R2 - 6	60
S40432000	R2 - 6-1	60
S40433000	R2 - 6-2	60
S40435000	R2 - 32	60
S40436000	R2 - 32-1	60
S40437000	R1 - 15	56
	R1 - 31	56
	R1 - 33	56
	R2 - 33	60
S40438001	P - 1	50
S40439001	P - 1-1	50
S40440001	P - 1-2	50
S40445009	P - 3	50
S40447000	P - 3-1	50
S40448000	P - 3-3	50
S40449001	R1 - 50-1	56
S40451009	P - 4	50
S40452009	P - 4-1	50
S40453000	P - 5	50
S40454000	P - 7	50
S40455000	P - 3-5	50
S40456000	R1 - 9	56
S40457000	R1 - 10	56
S40458000	R1 - 11	56
S40460000	R1 - 13	56
S40461000	R1 - 14	56
S40462000	R1 - 14-1	56
	R1 - 30-1	56
S40463000	R1 - 32	56
S40464000	R1 - 17	56
S40467000	R1 - 18	56
S40468000	R1 - 19	56
S40469000	R1 - 24	56
S40470000	R1 - 25	56
S40471000	R1 - 26	56
S40472000	R1 - 27	56
S40473000	R1 - 60-5	58
S40474000	R1 - 61	58
S40475000	R1 - 67	58
S40476000	R1 - 69	58
S40477000	R1 - 71	58
S40478000	R1 - 72	58
S40481000	R1 - 81	58
S40485001	R1 - 50	56
S40486000	R1 - 76	58

From the library of: Diamond Needle Corp

CODE	REF.NO.	Page
S40489001	T - 2	62
S40491001	R1 - 50-4	56
S40492001	R1 - 50-14	56
S40493001	R1 - 50-14-1	56
S40494000	R1 - 50-14-2	56
S40495001	R1 - 50-18	58
S40496000	W - 1-1-3	66
S40497000	R1 - 80	58
S40499009	P - 4-2	50
S40500000	R1 - 14-2	56
S40503000	R1 - 87	58
S40504000	P - 13	50
S40505000	P - 17	50
S40508000	R1 - 20	56
S40509000	R1 - 77	58
S40510000	R1 - 22	56
S40511001	P - 3-4	50
S40513009	R1 - 60	58
S40518000	D4 - 473	26
S40519000	W - 10-8	66
S40520009	W - 10	66
S40639001	Z - 17-8	68
S40641001	Z - 17-17	68
S40643001	Z - 17-18	68
S40644001	Z - 17-19	68
S41511001	D1 - 1	14
S41512001	D1 - 7	14
S41513001	D1 - 21	14
S41514001	D1 - 26	14
S41515001	D1 - 30	14
S41516001	D1 - 34	14
S41517000	D1 - 100	14
S41518000	D1 - 106	14
S41519001	D1 - 109	14
S41520001	D1 - 114	14
S41521000	D1 - 118	14
S41522000	D1 - 118-1	14
S41523000	D1 - 118-2	14
S41524000	D1 - 118-3	14
S41525001	D1 - 120	14
S41526001	D1 - 124	14
S41527001	D1 - 129	14
S41528001	D2 - 131	16
S41529001	D2 - 133	16
S41530001	D2 - 136	16
S41531001	D2 - 150	16
S41532001	D2 - 150-1	16
S41533000	D2 - 150-2	16
S41534000	D2 - 153	16
S41535000	D2 - 153-1	16
S41536001	D2 - 156	16
S41537000	D2 - 157	16
S41538000	D2 - 157-1	16
S41539001	D2 - 159	16
S41540000	D2 - 191	16
S41541001	D2 - 199	16
S41542001	D2 - 211	16
S41543000	D2 - 220	18
S41544001	D2 - 214	16
S41545001	D2 - 216	16
S41548000	D2 - 225	18
S41549000	D2 - 225-1	18
S41550000	D2 - 226	18

CODE	REF.NO.	Page
S41551001	D2 - 230	18
S41552001	D2 - 233	18
S41553000	D2 - 237	18
S41556101	D2 - 251	18
S41557001	D2 - 254	18
S41558001	D2 - 255	18
S41559000	D2 - 257	18
S41560001	D2 - 261	18
S41561001	D2 - 262	18
S41562009	D3 - 300	20
S41563109	D2 - 265	18
S41564001	D3 - 304	20
S41565001	D3 - 307	20
S41566001	D3 - 310	20
S41567001	D3 - 314	20
S41568000	D3 - 320	20
S41569000	D3 - 320-1	20
S41570001	D3 - 322	20
S41571001	D3 - 324	20
S41572001	D3 - 325	20
S41573001	D3 - 328	20
S41574001	D3 - 329	20
S41575001	D3 - 331	20
S41576001	D3 - 332	20
S41577001	D3 - 336	20
S41578001	D3 - 337	20
S41579001	D3 - 341	20
S41580001	D3 - 342	20
S41581000	H - 6	38
S41582000	D3 - 348	20
S41583001	D3 - 348-1	20
S41584001	D3 - 349	20
S41585001	D3 - 350	20
S41585001	D3 - 352	20
S41586001	D3 - 353	20
S41587001	D3 - 355	20
S41588001	D3 - 358	22
S41589001	D3 - 360	22
S41590001	D3 - 361	22
S41591001	D3 - 363	22
S41592001	D3 - 367	22
S41594001	D3 - 343	22
S41595001	D3 - 344	22
S41596001	D3 - 375	22
S41597001	D4 - 404	24
S41598000	D4 - 408	24
S41600000	D4 - 420	24
S41601001	D4 - 551	28
S41602000	D4 - 435	24
S41603001	D4 - 436	24
S41604001	D3 - 380	22
S41605001	Z - 20	70
S41606000	D4 - 442	24
S41607001	D4 - 484	26
S41608001	D4 - 485	26
S41609000	D4 - 494	26
S41610001	D4 - 495	26
S41611001	D4 - 497	26
S41612001	D4 - 502	26
S41613001	D4 - 514	26
S41614001	D4 - 552	28
S41615001	D4 - 522	26
S41618001	D4 - 487	26

CODE	REF.NO.	Page
S41619001	D4 - 515	26
S41620009	D4 - 480	26
S41621001	D4 - 400	24
S41622001	D2 - 234	18
S41623001	Z - 41	70
	D2 - 241	18
	D2 - 241	18
S41624001	Z - 42	70
	D2 - 242	18
	D2 - 242	18
S41625001	D2 - 235	18
S41626001	D2 - 243	18
S41627001	D2 - 244	18
S41628001	S - 15-1	60
S41629001	S - 15-2	60
S41630001	D2 - 200	16
S41631000	Q - 21	52
S41632000	Q - 20	54
S41633000	Q - 20-1	54
	Q - 21-1	52
S41634000	Q - 21-2	52
S41635000	C2 - 14	12
S41636000	Q - 55	52
S41637000	Q - 10	52
S41638001	W - 1-1	66
S41639001	W - 1	66
S41640001	W - 1-1	66
S41641000	Q - 1	52
S41669009	A1 - 18	2
S41670009	A1 - 21	2
S41671009	A1 - 21-1	2
S41672000	A1 - 21-2	2
S41673001	A1 - 85	2
S41674000	A1 - 85-2	2
S41675109	A1 - 15	2
S41677001	B - 1	8
S41678001	B - 3	8
S41679001	B - 14	8
S41680001	B - 14-1	8
S41683000	B - 19	8
S41684000	B - 21	8
S41685001	B - 23	8
S41686001	B - 24	8
S41687001	B - 25	8
S41688000	B - 30	8
S41689001	B - 33	8
S41691001	B - 36	8
S41692001	B - 37	8
S41693001	B - 38	8
S41694001	B - 39	8
S41695001	B - 40	8
S41696001	B - 14-6	8
S41697001	B - 34	8
S41698001	C1 - 1	10
S41699000	C1 - 1-1	10
S41700001	C1 - 2	10
S41701001	C1 - 6	10
S41702001	C1 - 6-6	10
S41703000	C1 - 11	10
S41704001	C1 - 12	10
S41705001	C1 - 14	10
S41706001	C1 - 31	10
S41707001	C1 - 37	10

From the library of: Diamond Needle Corp

CODE	REF.NO.	Page
S41710001	E - 8	30
S41712001	E - 19	30
	F - 47	32
S41715001	G1 - 18	36
	G1 - 46	36
S41716000	G1 - 50	36
S41719001	J - 1	40
S41721001	J - 1-1	40
S41722001	J - 1-2	40
S41723001	J - 1-3	40
S41724001	J - 1-4	40
S41725001	J - 1-7	40
S41726001	J - 1-16	40
S41727001	J - 1-17	40
S41728001	J - 1-22	40
S41729001	J - 6	40
S41730001	J - 10	40
S41731001	J - 14	40
S41734001	L - 18	44
S41735001	L - 40	44
S41737001	L - 43	44
S41738001	F - 77	34
	L - 49	46
S41741000	N - 1	48
S41742000	N - 2	48
S41745001	A2 - 1	4
S41746000	A2 - 5	4
S41747009	A2 - 7	4
S41748001	A2 - 8	4
S41749001	A2 - 11	4
S41750001	A2 - 13	4
S41751001	A2 - 15	4
S41752001	A2 - 18	4
S41753001	A2 - 19	4
S41754000	A2 - 22	4
S41757001	A2 - 26	4
S41758001	A2 - 28	4
S41759001	A2 - 30	4
S41760001	A2 - 32	4
S41761001	A2 - 36	4
S41762009	A2 - 40	4
S41763009	A1 - 45	2
S41764009	A1 - 46	2
S41765009	A2 - 48	4
S41767000	A2 - 50	4
S41768001	A2 - 54	4
S41769001	A2 - 55	4
S41770009	A2 - 71	6
S41771001	A2 - 72	6
S41772009	A2 - 78	6
S41773009	A2 - 78-1	6
S41774001	A2 - 81	6
S41777001	C2 - 1	12
S41778001	C2 - 1-1	12
S41780001	C2 - 1-2	12
S41782001	C2 - 1-3	12
S41783000	C2 - 1-4	12
S41784000	C2 - 1-5	12
S41785001	C2 - 4	12
S41786000	C2 - 6	12
S41787001	C2 - 7	12
S41789001	C2 - 7-1	12
S41791000	C2 - 7-6	12

CODE	REF.NO.	Page
S41792000	C2 - 7-7	12
S41794001	C2 - 7-8	12
S41796001	C2 - 7-12	12
S41801001	C2 - 8	12
S41802001	C2 - 20	12
S41803001	Z - 1	68
	Ga2 - 10	72
S41803041	Ga2 - 41	72
S41803042	Ga2 - 42	72
S41803043	Ga2 - 43	72
S41803044	Ga2 - 44	72
S41803045	Ga2 - 45	72
S41803046	Ga2 - 46	72
S41803047	Ga2 - 47	72
S41803048	Ga2 - 48	72
S41803049	Ga2 - 49	72
S41803050	Ga2 - 50	72
S41803051	Ga2 - 51	72
S41803052	Ga2 - 52	72
S41803053	Ga2 - 53	72
S41803054	Ga2 - 54	72
S41803055	Ga2 - 55	72
S41803056	Ga2 - 56	72
S41803057	Ga2 - 57	72
S41803058	Ga2 - 58	72
S41803059	Ga2 - 59	72
S41803060	Ga2 - 60	72
S41803061	Ga2 - 61	72
S41803062	Ga2 - 62	72
S41803063	Ga2 - 63	72
S41803064	Ga2 - 64	72
S41803065	Ga2 - 65	72
S41803066	Ga2 - 66	72
S41803067	Ga2 - 67	72
S41803068	Ga2 - 68	72
S41803069	Ga2 - 69	72
S41803070	Ga2 - 70	72
S41804001	C2 - 28	12
S41808000	F - 4	32
S41809000	F - 6	32
S41810001	F - 12	32
S41811000	F - 16	32
S41812001	F - 17	32
S41813001	F - 18	32
S41814000	F - 22	32
S41815001	F - 25	32
S41819001	F - 27	32
S41820001	F - 28	32
S41821001	F - 32	32
S41822001	F - 34	32
S41823001	F - 35	32
S41824001	F - 35-2	32
S41825001	F - 42	32
S41826001	F - 42-1	32
S41829001	F - 52	32
S41830001	F - 55	34
S41831001	F - 55-1	34
S41832001	F - 57	34
S41833001	F - 59	34
S41834000	F - 61	34
S41836001	F - 63	34
S41837000	F - 68	34
S41838001	F - 69	34

CODE	REF.NO.	Page
S41839001	F - 71	34
S41840001	F - 72	34
S41841009	F - 82	34
S41842000	F - 83	34
S41843009	F - 86	34
S41844009	F - 87	34
S41845000	F - 89	34
S41846001	F - 91	34
S41847009	F - 93	34
S41848000	F - 95	34
S41849000	F - 97	34
S41850001	F - 56	34
S41852000	G2 - 2	38
S41853001	G2 - 3	38
S41855001	G2 - 5	38
S41856000	G2 - 9	38
S41857001	G2 - 11	38
S41859009	K - 1	42
S41860009	K - 1-1	42
S41861000	K - 1-9	42
S41862000	K - 1-10	42
S41863009	K - 2	42
S41864009	K - 4	42
S41865001	H - 2	38
S41866001	H - 4	38
S41867000	H - 5	38
S41870001	H - 7	38
S41871001	H - 11	38
S41872001	H - 21	38
S41873001	H - 25	38
S41874000	M - 1	48
S41877001	M - 2	48
S41878001	M - 6	48
S41881000	U - 1	62
S41882001	U - 2	62
S41883009	U - 4	62
S41884001	U - 6	62
S41885009	V - 1	64
S41886009	V - 1	64
S41887009	V - 1-1	64
S41888009	V - 4	64
S41889001	R1 - 94	58
S41890009	V - 9	64
S41891001	V - 14	64
S41892009	V - 16	64
S41893001	V - 1-2	64
S41894001	V - 1-2	64
S41895001	V - 30	64
S41896000	V - 39	64
S41897000	V - 40	64
S41898009	V - 41	64
S41899009	V - 43	64
S41900009	V - 43	64
S41901009	Z - 2	68
S41903001	Z - 18	70
S41906001	W - 8	66
S41907001	W - 8-1	66
S41908001	W - 8-5	66
S41909000	V - 31	64
S41910009	V - 50	64
S41911001	D3 - 347	20
S41912001	D2 - 142	16
S41913000	D2 - 146	16

From the library of: Diamond Needle Corp

CODE	REF.NO.	Page
S41914000	D2 - 148	16
S41916000	Q - 72	52
S41925001	D4 - 449	24
S41926001	D4 - 456-2	24
S41927001	D4 - 456-3	24
S41931001	D2 - 246	18
S41932001	D2 - 247	18
S41933001	D2 - 248	18
S41935000	H - 17	38
	Q - 79	52
	C2 - 15	12
S41936000	H - 15	38
S41937000	Q - 80	54
S41938000	Q - 51	52
	Q - 52	52
	Q - 68	52
S41939000	Q - 53	52
	Q - 69	52
S41940000	Q - 66	52
	Q - 67	52
	A2 - 24	4
S41941000	Q - 62	52
	Q - 64	52
S41943000	F - 66	34
	H - 20	38
	Q - 58	52
	Q - 60	52
	Q - 63	52
	C2 - 32	12
S41959001	S - 15	60
S41960001	D1 - 17	14
S41961000	R1 - 14-3	56
S41963000	R1 - 14-4	56
S41964000	P - 19	50
	R2 - 35	60
S41965001	R1 - 89	58
S41967000	R1 - 23	56
S41969000	P - 18	50
S41972000	R1 - 21	56
S41975000	R2 - 1	60
S41976000	R2 - 2	60
S42227009	A1 - 29	2
S43402000	R1 - 30	56
S43634001	D2 - 270	18
U32744000	T - 1-5	62
0A4301005	T - 1-6	62
0A5300605	P - 3-6	50
0A5301005	P - 3-7	50
0A5301405	R1 - 50-3	56
0A5400806	P - 2	50
	D2 - 193	16
	D2 - 266	18
	R1 - 36	56
0A5401006	Q - 26	52
	D1 - 130	14
	R1 - 88	58
004400814	D2 - 147	16
	D3 - 330	20
	D4 - 486	26
008300604	K - 2-3	42
	W - 1-1-4	66
	A1 - 47	2
	R1 - 50-19	58

CODE	REF.NO.	Page
008300604	R1 - 60-3	58
008400604	P - 6	50
	U - 5	62
	V - 13	64
	V - 17	64
	V - 42	64
	A2 - 49	4
	C2 - 5	12
012060636	U - 3	62
	A2 - 27	4
	A2 - 29	4
	A2 - 67	6
	D1 - 113	14
	D2 - 215	16
012400436	J - 1-28	40
	Z - 19	70
	D2 - 213	16
	D2 - 236	18
	D2 - 250	18
	D3 - 354	20
	D3 - 359	22
	D3 - 362	22
	D4 - 421	24
	D4 - 424	24
	D4 - 432	24
	D4 - 434	24
012500536	F - 8	32
	F - 33	32
	F - 41	32
	F - 43	32
	D2 - 134	16
	D2 - 232	18
013660612	J - 1-24	40
013710512	F - 36-2	32
013719412	F - 19	32
013760612	E - 15	30
014060622	D4 - 426	24
014060632	Z - 17-18-1	68
014300332	K - 2-8	42
014500522	W - 10-22	66
014680422	K - 2-11	42
	L - 42	44
	C1 - 6-9	10
	D4 - 441	24
014680622	E - 3	30
	L - 7-2	44
014760622	B - 15	8
	B - 31	8
	E - 7	30
	E - 10	30
	F - 21	32
	L - 33	44
	P - 12	50
	C1 - 1-4	10
	C1 - 1-7	10
	C1 - 5-4	10
	C1 - 6-10	10
	C1 - 10	10
	C1 - 13	10
	C1 - 21	10
	C1 - 30	10
014770622	B - 12	8
	E - 13-1	30

CODE	REF.NO.	Page
014770622	L - 2	44
	L - 22	44
014780622	B - 4	8
017086006	A2 - 58	4
	D1 - 3	14
018051636	D3 - 305	20
018061222	Q - 2	52
018061236	V - 51	64
	A2 - 37	4
018061436	D2 - 143	16
	D2 - 151	16
018061636	A2 - 14	4
	A2 - 20	4
	A2 - 68	6
	A2 - 73	6
	D1 - 121	14
	D1 - 125	14
018062036	A2 - 41	4
	D1 - 8	14
	D1 - 102	14
018062536	D3 - 302	20
	D4 - 402	24
018063022	D1 - 107-1	14
	D1 - 115-2	14
018063036	D1 - 27	14
	D1 - 35	14
018065022	W - 8-2	66
018065036	P - 11	50
018081236	P - 14	50
018081636	V - 44	64
018082036	V - 6	64
018300622	D4 - 540	28
018300636	D4 - 474	26
018300822	D4 - 527	26
018301236	D4 - 475	26
	R1 - 68	58
018400636	F - 60	34
	F - 92	34
	S - 15-3	60
	W - 1-2	66
	C2 - 27	12
	D3 - 376	22
	R1 - 50-10	56
018400836	H - 12	38
	H - 22	38
	H - 26	38
	V - 10	64
	A2 - 82	6
	C2 - 7-9	12
	C2 - 31	12
	D2 - 271	18
	D3 - 316	20
	D3 - 323	20
	D3 - 338	20
	D3 - 345	20
	D3 - 364	22
	D3 - 368	22
	D3 - 382	22
	D4 - 467	26
	D4 - 503	26
	R1 - 95	58
	R1 - 98	58
018401036	H - 8	38

From the library of: Diamond Needle Co.

CODE	REF.NO.	Page
018401036	C2 -7-5	12
	C2 -9	12
	C2 -21	12
	D1 -18	14
	D2 -201	16
	D2 -263	18
	D3 -308	20
	D3 -311	20
	D3 -317	20
	D3 -333	20
	D4 -409	24
	D4 -437	24
	D4 -443	24
	D4 -451	24
	D4 -457	24
	D4 -459	24
018401222	U -7	62
	D4 -537	28
	R2 -3	60
018401236	K -2-4	42
	A2 -74	6
	D4 -553	28
	R1 -91	58
018401422	D4 -530	28
018401636	C2 -7-2	12
	D2 -258	18
	D4 -511	26
018402036	R1 -109	58
018402536	D2 -227	18
018403036	A2 -56	4
018405032	C1 -16	10
018500636	C2 -3	12
018500836	C2 -2	12
018501036	B -22	8
	A2 -16	4
	C2 -1-7	12
	D2 -252	18
018501236	A2 -2	4
	A2 -31	4
	D2 -217	16
	D4 -405	24
018501422	E -20	30
	F -48	32
018501436	M -3	48
018501636	M -7	48
	C2 -1-6	12
	C2 -17	12
	D2 -221	18
	D4 -481	26
	R1 -70	58
018502036	R1 -50-20	58
018503036	Q -22	52
018503536	D4 -492	26
018680822	B -41	8
018681022	L -11	44
018681232	B -27	8
021060206	P -23	50
	A2 -6	4
	A2 -90	6
021080206	A2 -61	4
	D1 -6	14
	D1 -16	14
	D1 -39	14

CODE	REF.NO.	Page
021160303	V -1-5	64
021200203	V -1-3	64
021300103	W -10-5	66
	D4 -478	26
021300206	Q -82	54
	S -15-10	60
021300303	R1 -50-14-4	56
021400202	W -10-20	66
	D4 -448	24
021400206	R1 -3	56
	R1 -110	58
021400216	R1 -50-7	56
	R1 -50-11	56
021400316	D3 -321	20
021500102	D4 -516	26
021500106	Q -33	52
	Z -17-10-3	68
	Z -17-17-1	68
	Z -17-18-2	68
	Z -17-19-1	68
021500216	D2 -160	16
	D2 -224	18
021680202	J -15	40
	K -1-7	42
022120306	V -48-3	64
	V -49	64
025030233	W -10-3	66
	W -10-16	66
025030236	K -2-24	42
	S -15-9	60
	D4 -477	26
025030335	F -42-10	32
025040136	C2 -23	12
025040233	W -10-13	66
025040236	H -10	38
	H -14	38
	H -24	38
	H -28	38
	S -15-5	60
	V -11	64
	A2 -35	4
	A2 -75	6
	A2 -83	6
	C2 -7-4	12
	C2 -11	12
	C2 -29	12
	D1 -20	14
	D2 -138	16
	D2 -198	16
	D2 -260	18
	D2 -268	18
	D2 -273	18
	D3 -335	20
	D3 -340	20
	D3 -366	22
	D3 -370	22
	D3 -378	22
	D3 -384	22
	D4 -439	24
	D4 -445	24
	D4 -453	24
	D4 -461	24
	D4 -469	26

CODE	REF.NO.	Page
025040236	D4 -471	26
	D4 -513	26
	D4 -555	28
	R1 -50-8	56
	R1 -93	58
	R1 -97	58
	R1 -100	58
025050236	M -5	48
	Q -31	52
	A2 -4	4
	C2 -19	12
	D4 -407	24
	D4 -483	26
	R1 -50-21	58
025060232	Q -4	52
	W -12	66
025060236	V -52	64
	A2 -38	4
	A2 -43	4
	A2 -70	6
	D1 -123	14
	D2 -145	16
025060336	P -21	50
025080236	P -16	50
	V -7-2	64
	V -4-3	64
025100132	A2 -6-5	6
025100236	D1 -119	14
025350236	D4 -504	26
025680132	L -1-13	44
025680232	K -1-13	42
	L -3-9	44
	G1 -8	36
026050136	D2 -219	16
	D2 -223	18
028030242	D4 -528	28
	D4 -541	28
028030243	W -10-4	66
	W -10-10	66
	W -10-17	66
028030246	S -15-8	60
	D2 -190	16
	D4 -456-5	24
	D4 -476	26
028040242	C2 -22	12
	D4 -531	28
	D4 -538	28
028040246	H -9	38
	H -13	38
	H -23	38
	H -27	38
	S -15-4	60
	V -12	64
	W -1-3	66
	A2 -34	4
	A2 -84	6
	A2 -87	6
	C2 -7-3	12
	C2 -7-14	12
	C2 -10	12
	C2 -26	12
	C2 -30	12
	D1 -19	14



CODE	REF.NO.	Page
028040246	D2 - 202	16
	D2 - 210	16
	D2 - 259	18
	D2 - 264	18
	D2 - 267	18
	D2 - 272	18
	D3 - 309	20
	D3 - 312	20
	D3 - 318	20
	D3 - 327	20
	D3 - 334	20
	D3 - 339	20
	D3 - 346	20
	D3 - 357	20
	D3 - 365	22
	D3 - 369	22
	D3 - 377	22
	D3 - 383	22
	D4 - 438	24
	D4 - 444	24
	D4 - 452	24
	D4 - 460	24
	D4 - 468	26
	D4 - 512	26
	D4 - 554	28
	R1 - 92	58
	R1 - 96	58
	R1 - 99	58
028050246	F - 65	34
	M - 4	48
	Q - 23	52
	Q - 32	52
	Z - 17-10-2	68
	A2 - 3	4
	C2 - 18	12
	D2 - 161	16
	D2 - 162	16
	D2 - 218	16
	D2 - 222	18
	D2 - 253	18
	D3 - 306	20
	D4 - 406	24
	D4 - 482	26
028060242	Q - 3	52
	W - 8-3	66
028060246	P - 22	50
	V - 53	64
	A2 - 42	4
	A2 - 69	6
	D1 - 11	14
	D1 - 28	14
	D1 - 37	14
	D1 - 103	14
	D1 - 122	14
	D1 - 126	14
	D2 - 144	16
	D2 - 152	16
	D3 - 303	20
	D4 - 403	24
028080242	D1 - 23	14
	D1 - 32	14
028080246	P - 15	50
	V - 8	64

CODE	REF.NO.	Page
028080246	V - 46	64
	A2 - 60	4
	D1 - 4	14
028260242	K - 2-29	42
028350242	L - 21-6	44
028350243	F - 42-9	32
028680242	F - 55-4	34
	G1 - 9	36
031451603	R1 - 107	58
031452206	Z - 17-2-2	68
	Z - 17-19-2	68
037301215	A2 - 78-3	6
039411215	V - 27	64
047301042	K - 2-18	42
048020342	W - 10-7	66
048030346	D4 - 472	26
048040342	C1 - 6-7	10
048050142	D2 - 212	16
	D4 - 496	26
	D4 - 498	26
048060342	L - 32	44
	C1 - 23	10
048070342	L - 19	44
048080342	E - 18	30
	F - 46	32
	A2 - 64	4
048100142	F - 13	32
048120142	D2 - 238	18
048130242	D4 - 427	24
048150142	B - 7	8
	D1 - 110	14
048180142	C1 - 8	10
048260242	F - 3	32
	F - 9	32
048320242	D1 - 105	14
052300606	K - 2-30	42
	D4 - 557	28
052400606	R1 - 111	58
052400806	W - 10-19	66
	R1 - 53	58
	R1 - 55	58
	R1 - 57	58
052401605	R1 - 112	58
060300416	F - 88	34
060300516	D4 - 456-4	24
060300612	F - 90	34
	R1 - 50-13	56
060350812	J - 1-19	40
060400616	D2 - 150-3	16
060400816	D2 - 132	16
	D2 - 137	16
	D3 - 326	20
060660512	K - 2-16	42
060670512	G1 - 16	36
060670612	J - 9	40
	J - 11	40
060680712	L - 4	44
062060806	Z - 17-2-1	68
062300412	R2 - 7	60
062300502	D2 - 195	16
062300512	N - 3	48
	C1 - 35	10
062300616	K - 2-23	42

CODE	REF.NO.	Page
062300616	W - 10-9	66
	W - 10-15	66
	A2 - 80	6
062300806	R1 - 34	56
	R2 - 34	60
062301005	R1 - 50-14-3	56
062301006	S - 15-7	60
	R1 - 16	56
062302506	Q - 81	54
062400616	W - 10-12	66
	A2 - 53	4
062400816	D4 - 455	24
062401012	A1 - 22	2
062401016	A2 - 33	4
	D2 - 197	16
062501006	V - 1-7	64
	Z - 17-19-3	68
062501406	Z - 17-17-4	68
062660412	E - 14-3	30
	F - 42-3	32
062660712	E - 14-7	30
	F - 42-7	32
062670512	J - 1-18	40
	A1 - 86	2
	G1 - 27	36
	G1 - 39	36
	G2 - 8	38
	R2 - 12	60
062670612	B - 18	8
	J - 17	40
062671412	J - 8	40
062680612	A1 - 27	2
	C1 - 3	10
	C1 - 38	10
	G1 - 7	36
	G1 - 30	36
062680812	B - 14-6-1	8
	B - 34-1	8
	N - 4	48
062681012	A1 - 17	2
	C1 - 26	10
062681212	J - 5	40
	K - 1-12	42
062682012	J - 4	40
062710812	R1 - 62	58
062711212	A1 - 20	2
062761212	W - 11	66
062781412	B - 20	8
070688850	C1 - 15	10
	C1 - 24	10
072512260	F - 15	32
072600080	F - 5	32
	F - 11	32
072630260	B - 6	8
076002800	D1 - 104	14
076906800	D4 - 488	26
081003670	E - 12	30
	E - 17	30
	F - 40	32
	F - 45	32
100022004	K - 1-11	42
100022005	L - 24	44
	L - 25-3	44

From the library of: Diamond Needle Corp

CODE	REF.NO.	Page
100022005	W - 13	66
100032004	F - 79	34
	L - 51	46
	C1 - 33	10
100090004	E - 2	30
100136001	K - 1-3	42
100250001	B - 11	8
100257010	A1 - 85-3	2
	D4 - 525	26
100360003	F - 81	34
	L - 54	46
100402004	D4 - 465	26
100645003	C1 - 39	10
100887001	Z - 8	68
101482001	B - 32	8
101572101	Z - 40	70
101706001	B - 13	8
	E - 6-1	30
	C1 - 5-2	10
102630001	B - 16	8
102707002	C2 - 7-11	12
	C2 - 7-15	12
	R1 - 50-9	56
104449009	A1 - 12	2
104450109	K - 3	42
	A1 - 3	2
	A1 - 11	2
	A2 - 44	4
104567001	G1 - 21	36
104821009	A2 - 57	4
104833009	A2 - 39	4
105161004	D4 - 456-6	24
105234003	F - 55-3	34
105288001	D4 - 520	26
105299003	A2 - 10	4
106129002	L - 21-5	44
	A1 - 85-1-5	2
	A1 - 85-4	2
106147002	L - 14	44
106436001	G2 - 14	38
106588003	R1 - 50-23	58
106629002	F - 70	34
	F - 84	34
	F - 94	34
	K - 5	42
	A1 - 16	2
	G2 - 10	38
107017002	P - 4-4	50
107149001	G1 - 5	36
	G1 - 13	36
107321003	P - 4-3	50
107657001	F - 58	34
107779001	Z - 6	68
107780001	Z - 9	68
108265009	J - 1-6	40
109893002	J - 1-27	40
	L - 28	44
110161004	L - 27	44
	L - 37	44
110233001	L - 26	44
	L - 36	44
110367001	L - 31	44
	D2 - 231	18

CODE	REF.NO.	Page
110735002	B - 42	8
	K - 2-5	42
111140002	F - 78	34
	L - 50	46
111942001	K - 2-14	42
111943001	K - 2-15	42
112712001	J - 1-9	40
114483002	Z - 3	68
114486002	A2 - 79	6
115127001	F - 36-1	32
116920001	D1 - 111	14
117150001	R2 - 11	60
117934009	A1 - 5	2
118064001	Z - 13	68
118550001	D1 - 2	14
	D1 - 25	14
118735002	W - 8-4	66
118837001	Z - 39	70
120192000	Z - 16	68
120438001	E - 21	30
	F - 2	32
122257001	F - 29	32
122991000	Z - 15	68
126863001	Z - 17-5	68
132051001	B - 14-4	8
133172003	V - 1-6	64
138843001	Z - 17-12	68
140392009	A1 - 6	2
	A1 - 13	2
140647001	G2 - 6	38
140682001	Q - 20-5	54
	Q - 21-6	52
140726000	B - 5	8
140947002	D4 - 447	24
141542001	D4 - 534	28
141590001	K - 1-8	42
141786001	E - 1	30
142002001	Z - 10	68
142205001	Z - 7	68
142721001	Z - 12	68
142990001	Z - 17-15-3	68
142997001	Z - 17-7	68
144105000	J - 1-25	40
	K - 1-6	42
144110001	J - 1-26	40
	K - 1-4	42
144458001	B - 43	8
144504001	W - 10-21-3	66
144712001	B - 2-1	8
145318001	C1 - 32	10
145446001	J - 1-12	40
	K - 1-5	42
145478101	L - 9	44
145547001	G1 - 26	36
146124001	J - 1-5	40
146197001	K - 2-20	42
146354001	U - 8	62
	D2 - 154	16
148239001	F - 54	32
148417001	D4 - 518	26
148738000	G1 - 4	36
	G1 - 40	36
	G1 - 41	36

CODE	REF.NO.	Page
148813001	L - 21-4	44
148851001	J - 1-15	40
149547000	R1 - 51	58
149566109	J - 1-14	40
149796001	Z - 5	68
149864001	D4 - 464	26
149996001	A2 - 9	4
150172003	Z - 17-8-1	68
	Z - 17-16	68
150173003	Z - 17-9	68
150179002	Z - 17-10-1	68
150180001	Z - 17-3	68
150182000	Z - 17-4	68
150183000	Z - 17-15-2	68
150185009	Z - 17-11	68
150188009	Z - 17-13	68
150189109	Z - 17-1	68
150335001	Z - 14	68
150357001	R1 - 102	58
150594001	F - 20	32
151602002	F - 30	32
151626001	D4 - 490	26
151927001	G1 - 20	36
152231000	B - 10	8
152236001	B - 14-2	8
152237001	B - 14-3	8
152238001	B - 14-5	8
152245001	E - 4	30
152361001	K - 2-12	42
152362001	K - 2-13	42
152363001	K - 2-17	42
152364001	K - 2-19	42
152393200	V - 1-4	64
152507000	K - 2-21-2	42
152508000	K - 2-21-3	42
152509000	K - 2-21-4	42
152510000	R1 - 7	56
152566000	P - 1-1-2	50
	P - 1-2-3	50
	Z - 51	70
152645001	K - 2-22	42
152678001	E - 11	30
	E - 16	30
	F - 39	32
	F - 44	32
152683001	E - 14-4	30
	F - 42-4	32
152684101	E - 14-5	30
	F - 42-5	32
152686001	E - 100	30
	F - 100	34
152725000	D1 - 115-1	14
152743001	C1 - 1-2	10
	C1 - 6-5	10
152756001	C1 - 9	10
152760001	C1 - 7	10
152863001	R1 - 50-22	58
152889001	J - 16	40
152948001	G1 - 1	36
	G1 - 32	36
	G2 - 1	38
152956001	G1 - 42	36
152969001	G1 - 38	36

From the library of: Diamond Needle Corp.

